

Demonstration Board for the SA57-IHZ

INTRODUCTION

The DB74HU is designed to demonstrate the capabilities of the SA57 DC brush motor driver IC. This fully assembled demonstration allows the user to directly control the speed and direction of the motor. An onboard circuit controls the direction and provides four quadrant PWM signals to control the power outputs of the SA57. LEDs provide visual feedback for motor control status and fault indications. Provisions on the DB74HU allow the user to bypass the onboard control circuit and directly interface with the SA57 motor driver.

The DB74HU demonstrates proper layout techniques for the SA57 high current switching amplifier. The economical construction uses only a two-sided PCB and allows the SA57 to deliver peak power of over 1kW.

THERMAL CONSIDERATIONS:

The SA57 is available in a surface mount package which can deliver peak power of over 1kW. This presents an obvious and significant thermal challenge. The DB74HU offers a compact design which can deliver 17A peak current and dissipate approximately 20W in still air at 25°C ambient temperature. To use the DB74HU in higher power applications, use a fan or mount a heatsink with larger thermal mass. Although the SA57 is rated for operation from -25 to +85°C, the other components on the DB74HU are limited to 0 to 70°C ambient temperature.

CIRCUIT OPERATION

The DB74HU control circuit receives power via two terminal block connections. The Vs connection supplies power to drive the motor and must be above the under-voltage lockout threshold of the SA57, approximately 8.3V. The control circuit requires 12V for proper operation. A regulator on the DB74HU provides the 5V logic supply for the SA57. There are no special considerations for sequencing the two supplies.

Figure 2 (next page) shows the user control features of the DB74HU. The PWM duty cycle is controlled with the potentiometer. LED5 will illuminate when the 12V supply is connected. The DB74HU will power up with the SA57 disabled. The enable button will toggle the SA57 on and off with LED2 illuminating to indicate the enable status. Direction of the motor is similarly controlled with the button and is indicated by the LED.

The DB74HU monitors the Temperature warning status pin of the SA57. If this pin goes high LED4 illuminates and the enable circuit is forced to a disable status. The temperature LED is not latched and may stay illuminated only briefly while the temperature of the SA57 is above 135°C. The temperature decrease rapidly via the heatsink once the SA57 is disabled. The SA57 current limit feature is set to limit at approximately 15A to provide a demonstration of the full capabilities of the SA57. LED3 will illuminate if the SA57 cycle-by-cycle current limit circuit engages. The thermal and current limit features are robust, but will not protect the SA57 in all circumstances. The user must consider the worst case thermal and power dissipation conditions.

Push-button switches 1 and 2 trigger latches for direction and enable control, respectively. Diodes D7 & D8 and resistors R24, 25, 29 & 30 provide a means of bypassing the DB74HU control circuit. The 5V regulator, U3, provides 5V to the SA57, the latches and the status LEDs.

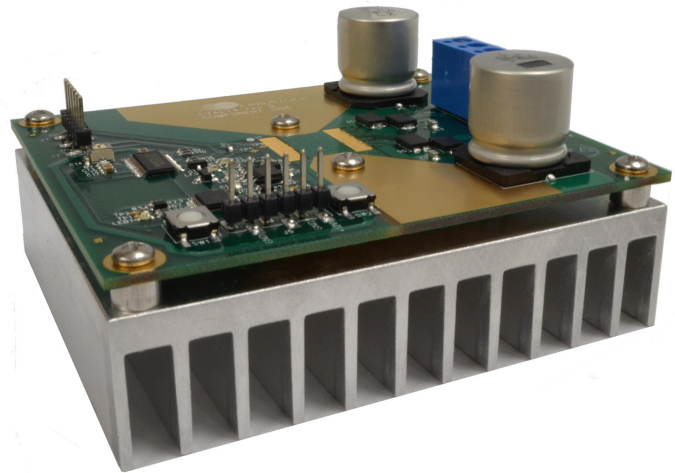

Figure 1 – User Control Features

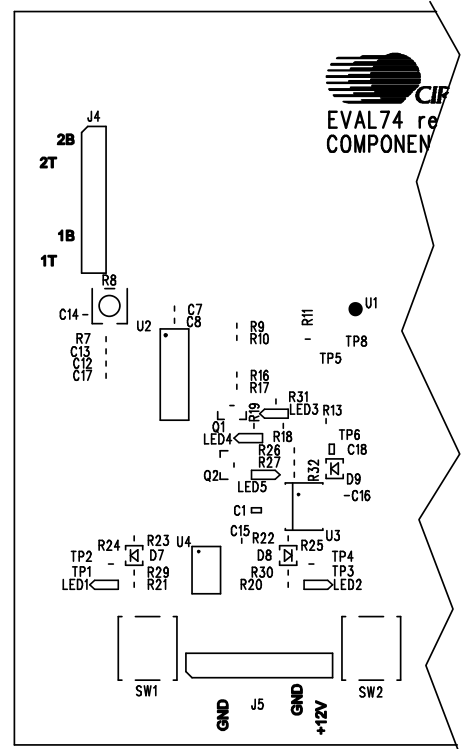
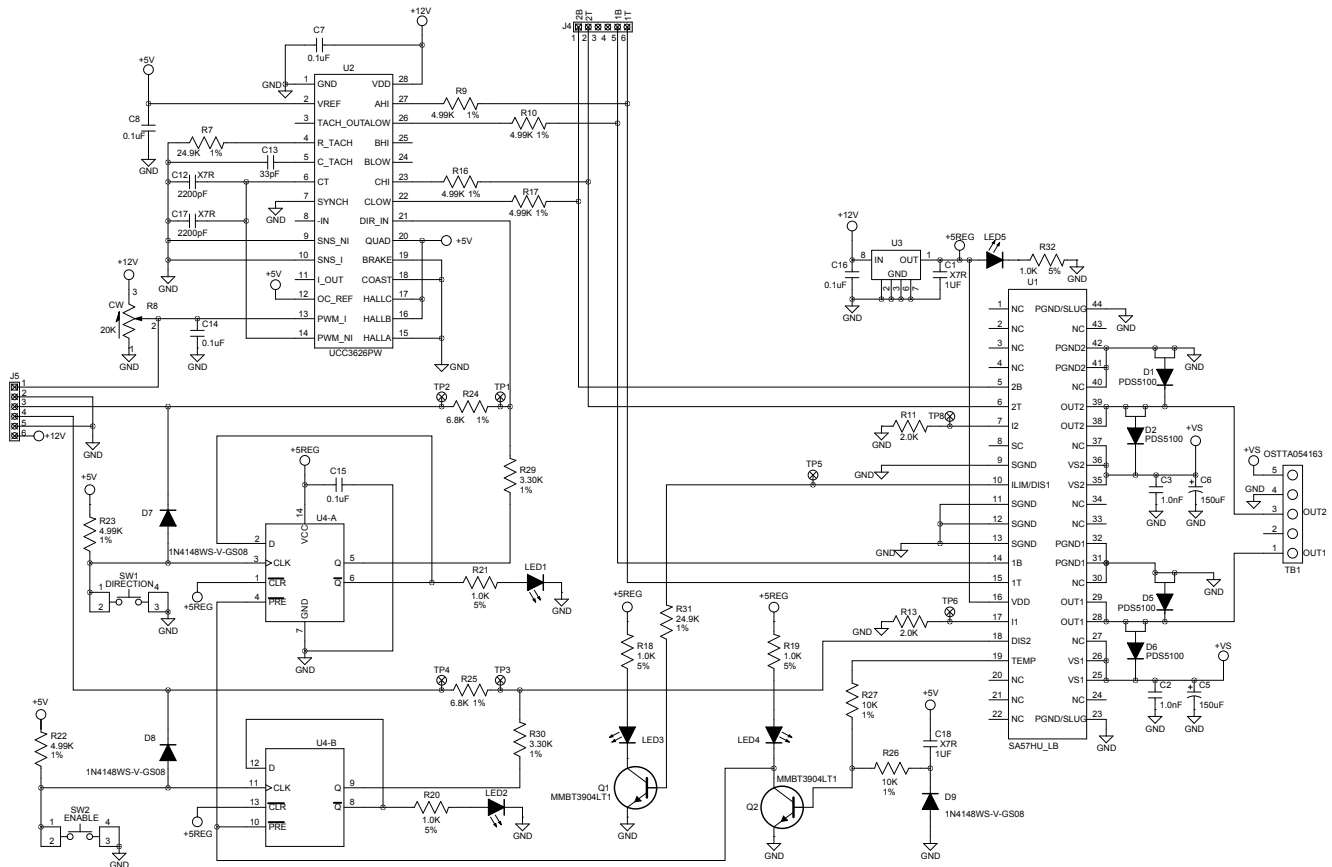

Figure 2 – Schematic



ENHANCING & BYPASSING THE DB74HU CONTROL CIRCUIT:

Connector J5 allows the user to bypass many of the manual control features of the DB74HU. A signal generator can control the duty cycle with a 2.5 to 7.5V signal, overriding the control potentiometer. A rising 5V edge on pin 3 or 4 of connector J5 will toggle the Direction or Enable latches, respectively. By jumping resistors R24 & R25, the latches are bypassed completely and the logic signals on pins 3 & 4 will directly control the direction and enable functions of the DB74HU. With these resistors jumped, the direction and enable LEDs will not represent the states of the DB74HU and the pushbuttons will have no effect on the operation. The Temperature disable feature of the DB74HU will also not function, although LED4 will continue to provide over-temperature status.

Connector J4 is connected directly to the PWM input pins of the SA57. This connector may be used to monitor the signals or to bypass the control IC on the DB74HU. The enable function is not controlled via these pins, although pulling all four input pins low provides the same effect. The Enable pushbutton and the connection via J5 are also effective as previously described. The circuit shown in figure 3 in the dashed box is a simple circuit that allows the user to monitor and control the enable or direction status remotely. Either feature can be toggled on the falling edge of the signal at the node labeled TOGGLE.

LAYOUT CONSIDERATIONS

A simple two layer construction is sufficient because of the convenient pinout of the SA57 input signals are routed into one side of the package and high power output signals are routed from the other side in 2 ounce copper. This eliminates the need to route control signals near motor connections where noise may corrupt the signals. Filling top and bottom layers with copper reduces inductive coupling from the high current outputs. 1nF capacitors with excellent high frequency characteristics bypass the Vs motor supplies on each phase. Two 150µF electrolytic capacitors provide a local, low inductance source to accommodate surge currents up to 17A. Six 100V Schottky

diodes conduct the commutation current via low forward voltage paths which reduces the power dissipation in the SA57. These diodes are rated for 5A continuous and are mounted close to the SA57 to reduce inductance in the commutating current loop. For applications with continuous currents less than 5A, the Schottky diodes may not be necessary if the higher forward voltage internal body diodes and the associated power dissipation are manageable during commutation cycles.

Figure 3 shows the top and bottom layouts of the DB74HU. Gerber files for the circuit board are available upon request.

Figure 3 – PCB Layout (not to scale)

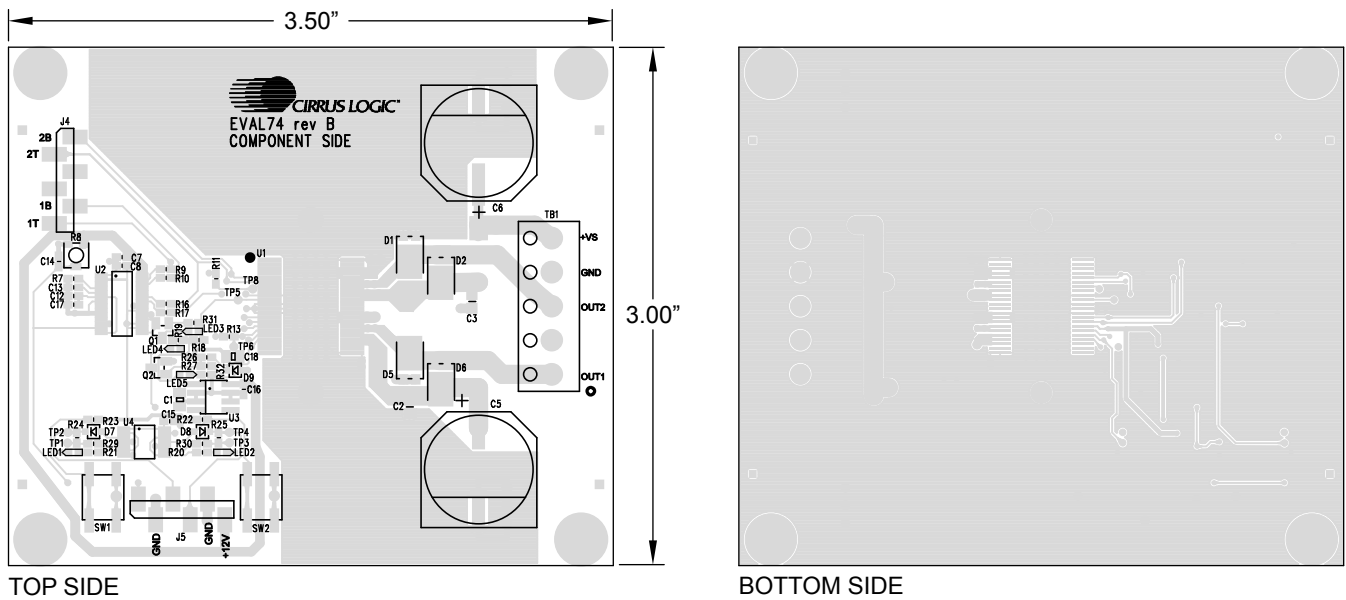

BILL OF MATERIALS

Designation	Description	P/N
C1,C18	CAP, 1.0uF, 16V	Kemet, C0805C105K4RAC
C13	CAP, 33pF, 50V	Kemet, C0603C330J5GACTU
C2,C3	CAP, 1.0nF,100V	Kemet,C0805C102J1GACTU
C5,C6	CAP, 150uF, 100V	Panasonic, EEVFK2A151M
C7,C8,C14,C15,C16	CAP, 0.1uF,16V	GRM188F51C104ZA01D
C12,C17	CAP, 2.2nF,50V	GRM188R71H222KA01D
D1,D2,D5,D6	Diode, 5A Schottky	Diodes Inc., DS5100
D7,D8,D9	IN4148	Vishay, 1N4148WS-V-GS08
J4, J5	Conn, 6 pin .100 ctrs	Samtec, TSM-106-01-T-SV
LED1, LED2, LED3, LED4, LED, Red		Lite-On, LTST-C190CKT
LED5,		
Q1,Q2	XTR, NPN	MMBT3904
R11,R13	RES 2.0K, 1%	Vishay,CRCW06032K00FKEA
R24,R25	RES, 6.8K	Vishay,CRCW06036K80FKEA
R26,R27	RES, 10K	Vishay,CRCW060310K0FKEA
R29,R30	RES, 3.3K	Vishay,CRCW06033K30FKEA
R18,R19,R20,R21,R32	RES, 1.0K, 5%	RK73B1JTDD102J
R7,R31	RES, 24.9K,1/10W, 1%	RK73H1JTDD2492F
R8	POT, 20K	muRata, PVG3A203C01
R9,R10,R16,R17,R22,R23	RES, 4.99K	CRCW06034K99FKEA
SW1,SW2	Pushbutton, SPST-NO	Panasonic, EVQ-Q2B01W
TB1	Terminal Block, 5 pos, 5mm	On Shore Tech, OSTTA0S4163
U1	SA57-HU-FH	Apex Precision Power, SA57-HU-FH
U2	UCC3626	Texas Instruments, UCC3626PW
U3	LM78L05	National Semiconductor, LM78L05ACMX/NOPB
U4	74AC74	Texas Instruments, SN74AC74PW
	Heatsink	Cirrus Logic, HS36, 2.8°/W
	PCB, 3.00" x 3.50"	Cirrus Logic, EVAL74
	Screw, #4-40 x 1/2"	18-8 SS Pan Head Phillips Screw, 91772A110
	Gap Pad, Thermal Interface, 40 mils thick, 1°C/W	GP5000S3S-0.040-02-43-NA

DB74HU QUICK START GUIDE

1. Connect the following:

Connection	Location	Indicator	Comment
Vs	TB1		9-60V
Ground	TB1		
Vctrl	J5-6	LED 2	12V
Motor Phase A	TB1		
Motor Phase B	TB1		

2. Apply 12V to Vctrl. LED 5 should light.
3. Apply voltage to Vs based on rated motor voltage, normally 12-48V.
4. Press ENABLE switch 3. LED 2 will light and motor should start.

ORDERING INFORMATION

DB74HU Demonstration Board includes one populated EVAL74 PCB and one SA57-HU-FH sample.

CONTACTING CIRRUS LOGIC SUPPORT

For all Apex Precision Power product questions and inquiries, call toll free 800-546-2739 in North America.

For inquiries via email, please contact apex.support@cirrus.com.

International customers can also request support by contacting their local Cirrus Logic Sales Representative.

To find the one nearest to you, go to www.cirrus.com

IMPORTANT NOTICE

Cirrus Logic, Inc. and its subsidiaries ("Cirrus") believe that the information contained in this document is accurate and reliable. However, the information is subject to change without notice and is provided "AS IS" without warranty of any kind (express or implied). Customers are advised to obtain the latest version of relevant information to verify, before placing orders, that information being relied on is current and complete. All products are sold subject to the terms and conditions of sale supplied at the time of order acknowledgment, including those pertaining to warranty, indemnification, and limitation of liability. No responsibility is assumed by Cirrus for the use of this information, including use of this information as the basis for manufacture or sale of any items, or for infringement of patents or other rights of third parties. This document is the property of Cirrus and by furnishing this information, Cirrus grants no license, express or implied under any patents, mask work rights, copyrights, trademarks, trade secrets or other intellectual property rights. Cirrus owns the copyrights associated with the information contained herein and gives consent for copies to be made of the information only for use within your organization with respect to Cirrus integrated circuits or other products of Cirrus. This consent does not extend to other copying such as copying for general distribution, advertising or promotional purposes, or for creating any work for resale.

CERTAIN APPLICATIONS USING SEMICONDUCTOR PRODUCTS MAY INVOLVE POTENTIAL RISKS OF DEATH, PERSONAL INJURY, OR SEVERE PROPERTY OR ENVIRONMENTAL DAMAGE ("CRITICAL APPLICATIONS"). CIRRUS PRODUCTS ARE NOT DESIGNED, AUTHORIZED OR WARRANTED TO BE SUITABLE FOR USE IN PRODUCTS SURGICALLY IMPLANTED INTO THE BODY, AUTOMOTIVE SAFETY OR SECURITY DEVICES, LIFE SUPPORT PRODUCTS OR OTHER CRITICAL APPLICATIONS. INCLUSION OF CIRRUS PRODUCTS IN SUCH APPLICATIONS IS UNDERSTOOD TO BE FULLY AT THE CUSTOMER'S RISK AND CIRRUS DISCLAIMS AND MAKES NO WARRANTY, EXPRESS, STATUTORY OR IMPLIED, INCLUDING THE IMPLIED WARRANTIES OF MERCHANTABILITY AND FITNESS FOR PARTICULAR PURPOSE, WITH REGARD TO ANY CIRRUS PRODUCT THAT IS USED IN SUCH A MANNER. IF THE CUSTOMER OR CUSTOMER'S CUSTOMER USES OR PERMITS THE USE OF CIRRUS PRODUCTS IN CRITICAL APPLICATIONS, CUSTOMER AGREES, BY SUCH USE, TO FULLY INDEMNIFY CIRRUS, ITS OFFICERS, DIRECTORS, EMPLOYEES, DISTRIBUTORS AND OTHER AGENTS FROM ANY AND ALL LIABILITY, INCLUDING ATTORNEYS' FEES AND COSTS, THAT MAY RESULT FROM OR ARISE IN CONNECTION WITH THESE USES.

Cirrus Logic, Cirrus, and the Cirrus Logic logo designs, Apex and Apex Precision Power are trademarks of Cirrus Logic, Inc. All other brand and product names in this document may be trademarks or service marks of their respective owners.