

## H-Bridge Motor Driver/Amplifiers

### FEATURES

- ◆ LOW COST COMPLETE H-BRIDGE
- ◆ SELF-CONTAINED SMART LOWSIDE/  
HIGHSIDE DRIVE CIRCUITRY
- ◆ WIDE SUPPLY RANGE: UP TO 80V
- ◆ 10A CONTINUOUS OUTPUT
- ◆ ISOLATED CASE ALLOWS DIRECT  
HEATSINKING
- ◆ FOUR QUADRANT OPERATION, TORQUE  
CONTROL CAPABILITY
- ◆ INTERNAL/PROGRAMMABLE PWM  
FREQUENCY GENERATION

### APPLICATIONS

- ◆ BRUSH TYPE MOTOR CONTROL
- ◆ CLASS D SWITCHMODE AMPLIFIER
- ◆ REACTIVE LOADS
- ◆ MAGNETIC COILS (MRI)
- ◆ ACTIVE MAGNETIC BEARING
- ◆ VIBRATION CANCELLING

### DESCRIPTION

The SA60 is a pulse width modulation amplifier that can supply 10A continuous current to the load. The full bridge amplifier can be operated over a wide range of supply voltages. All of the drive/control circuitry for the lowside and highside switches are internal to the hybrid. The PWM circuitry is internal as well, leaving the user to only provide an analog signal for the motor speed/direction, or audio signal for switchmode audio amplification. The internal PWM frequency can be programmed by an external integrator capacitor. Alternatively, the user may provide an external TTL-compatible PWM signal for simultaneous amplitude and direction control for four quadrant mode.

### BLOCK DIAGRAM

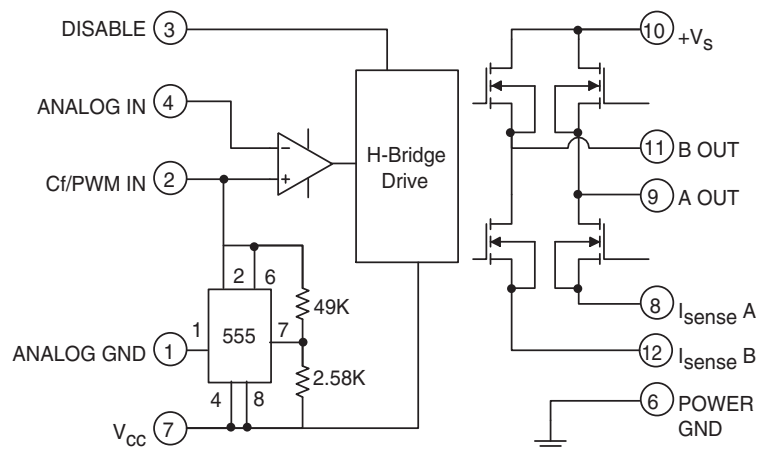

## 1. CHARACTERISTICS AND SPECIFICATIONS

### ABSOLUTE MAXIMUM RATINGS

Parameter	Symbol	Min	Max	Units
SUPPLY VOLTAGE, $+V_S$ (Note 4)			80	V
OUTPUT CURRENT, peak			15	A
LOGIC SUPPLY VOLTAGE, $V_{CC}$			16	V
POWER DISSIPATION, internal (Note 3)			156	W
TEMPERATURE, pin solder, 10s max.			260	°C
TEMPERATURE, junction (Note 2)			150	°C
TEMPERATURE RANGE, storage		-55	125	°C
OPERATING TEMPERATURE RANGE, case		-25	85	°C

**CAUTION**

The SA60 is constructed from MOSFET transistors. ESD handling procedures must be observed. The exposed substrate contains beryllia (BeO). Do not crush, machine, or subject to temperatures in excess of 850°C to avoid generating toxic fumes.

### SPECIFICATIONS

Parameter	Test Conditions <sup>1</sup>	Min	Typ	Max	Units
<b>INPUT</b>					
ANALOG INPUT VOLTAGES	$V_{CC} = 12V$				
A, B OUT = 50% Duty Cycle			$1/2 V_{CC}$		VDC
A OUT = 100% Duty Cycle High			$1/3 V_{CC}$		VDC
B OUT = 100% Duty Cycle High			$2/3 V_{CC}$		VDC
<b>PWM INPUT</b>					
PWM PULSE LOW VOLTAGE		0		0.8	VDC
PWM PULSE HIGH VOLTAGE		2.7		5.0	VDC
PWM FREQUENCY			45	250	KHz
DISABLE ON		2.7		$V_{CC}$	VDC
DISABLE OFF		0		0.8	VDC
<b>OUTPUT</b>					
$V_{DS}$ (ON) VOLTAGE, each MOSFET	$I_{DS} = 10A$		1.7	2.5	VDC
TOTAL $R_{ON}$ , both MOSFETs				0.45	$\Omega$
EFFICIENCY, 10A OUTPUT	$+V_S = 80A$		91		%
CURRENT, continuous		10			A
CURRENT, peak	$t = 100$ msec	15			A
SWITCHING FREQUENCY	$C_F = 270pF$		45		KHz
DEAD TIME			90		nS
<b>POWER SUPPLY</b>					
$+V_S$ VOLTAGE (Note 4)	$+V_S$ Current = Load Current			80	VDC
$V_{CC}$ VOLTAGE		9.5	12	15	VDC
$V_{CC}$ CURRENT	$V_{CC} = 12VDC$		28	36	mA
$+V_S$ CURRENT	Switching, no load, $V_S = 50V$		5		mA

Parameter	Test Conditions <sup>1</sup>	Min	Typ	Max	Units
<b>THERMAL</b> (Note 3)					
RESISTANCE, junction to case	Full temperature range, for each transistor			1.6	°C/W
RESISTANCE, junction to air	Full temperature range		30		°C/W
TEMPERATURE RANGE, case		-25		+85	°C

- NOTES: 1. (All Min/Max characteristics and specifications are guaranteed over the Specified Operating Conditions. Typical performance characteristics and specifications are derived from measurements taken at typical supply voltages and  $T_C = 25^\circ\text{C}$ ,  $V_{CC} = 12\text{VDC}$ ).
2. Long term operation at the maximum junction temperature will result in reduced product life. Derate power dissipation to achieve high MTTF.
3. Each of the two active output transistors can dissipate 78W.
4. Derate to 70V below  $T_C = +25^\circ\text{C}$ .

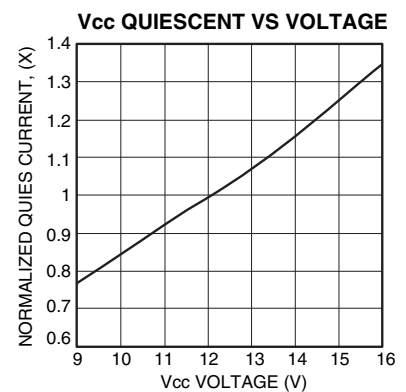
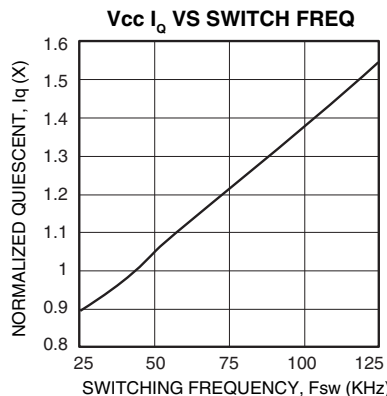
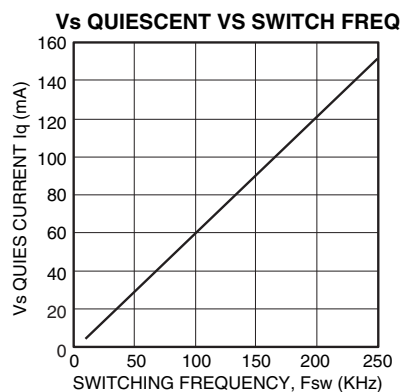
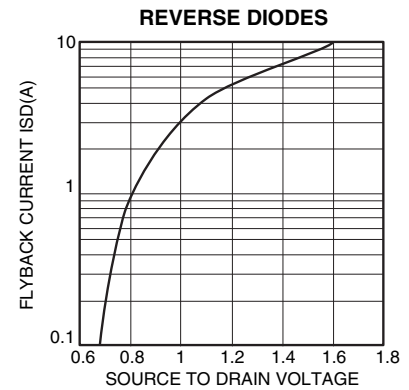
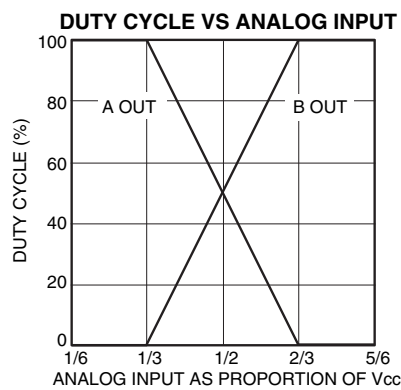
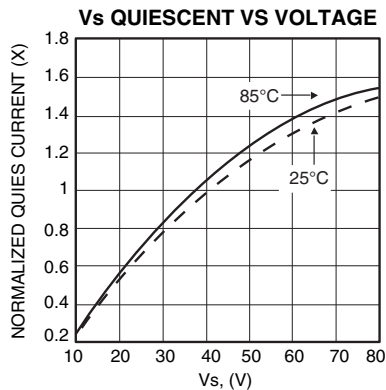
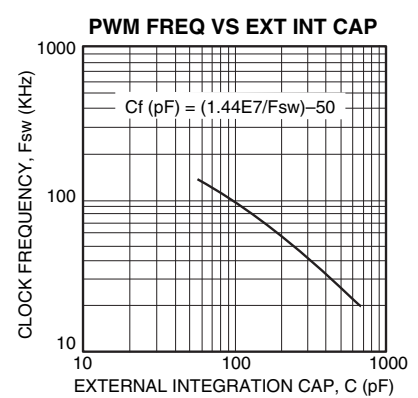
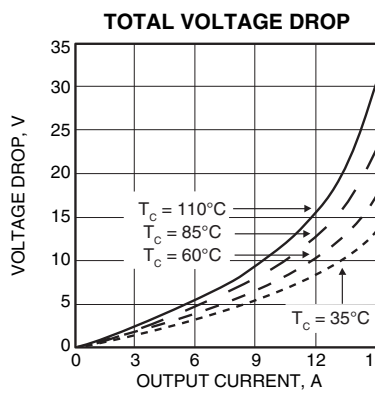
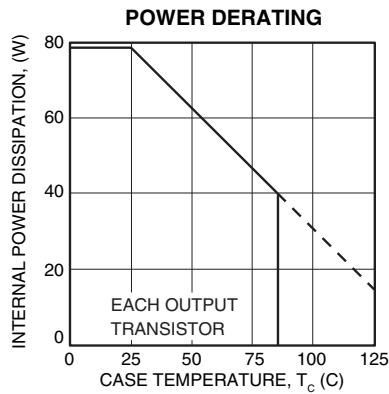

## EXTERNAL CONNECTIONS

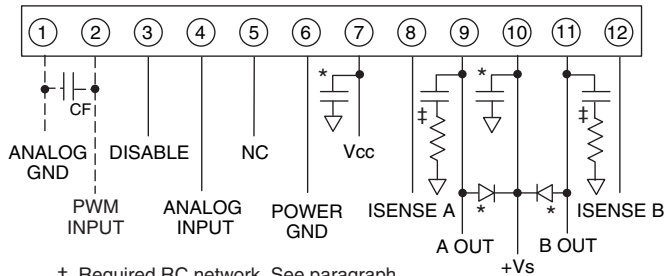

‡ Required RC network. See paragraph on transient shutdown.

\* Protection diodes are recommended for applications where +Vs exceeds 50V.



### 12-pin Power SIP PACKAGE STYLE DP

Formed Leads Available  
See package style EE

## TYPICAL APPLICATION

A wide variety of loads can be driven in either the voltage mode or the current mode. The most common applications use three external blocks: a low pass filter converting pulse width data to an analog output, a difference amplifier to monitor voltage or current and an error amplifier. Filter inductors must be suitable for square waves at the switching frequency (laminated steel is generally not acceptable). Filter capacitors must be low ESR and rated for the expected ripple current. A difference amplifier with gain of less than one translates the differential output voltage to a single feedback voltage. Dashed line connections and a higher gain difference amplifier would be used for current control. The error amplifier integrates the difference between the input and feedback voltages to close the loop.

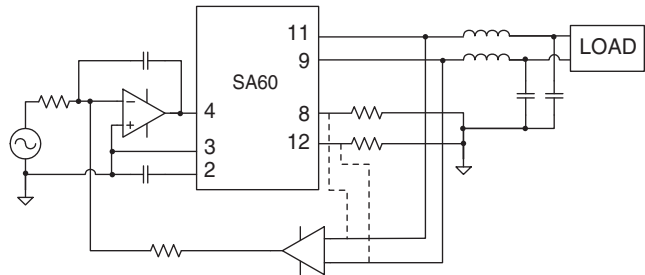

## GENERAL

Please read Application Note 30 on "PWM Basics". Refer to Application Note 1 "General Operating Considerations" for helpful information regarding power supplies, heat sinking and mounting. Visit [www.Cirrus.com](http://www.Cirrus.com) for design tools that help automate pwm filter design; heat sink selection; Apex Precision Power's complete Application Notes library; Technical Seminar Workbook; and Evaluation Kits.

## PWM OSCILLATOR – INTERNAL OR EXTERNAL

The SA60 contains an internal PWM oscillator whose frequency is determined by an external capacitor connected between pin 1 and pin 2. Maximum frequency is 125 kHz. The user may also disregard the internal PWM oscillator and supply the SA60 with an external TTL pulse generator up to 250KHZ.

## PIN DESCRIPTION

**V<sub>cc</sub>** - is the low voltage supply for powering internal logic and drivers for the lowside and highside MOSFETS. The supplies for the highside drivers are derived from this voltage.

**V<sub>s</sub>** - is the higher voltage H-bridge supply. The MOSFETS obtain the output current from this supply pin. The voltage on this pin is limited to +80V by the drive IC. The MOSFETS are rated at 100 volts.

**ISENSE A & B** - These are tied to power gnd directly or through sense resistors.

**ANALOG GND** - is the reference for the internal PWM oscillator. Connect this pin to pin 6. Connect low side of V<sub>cc</sub> supply and any other supply used to generate analog input signals to ANALOG GND.

**ANALOG INPUT** - is an analog input for controlling the PWM pulse width of the bridge. A voltage higher than V<sub>cc</sub>/2 will produce greater than 50% duty cycle pulses out of B OUT. A voltage lower than V<sub>cc</sub>/2 will produce greater than 50% duty cycle pulses out of A OUT. If using in the digital mode, bias this point at 1/2 the logic high level.

**DISABLE** - Is the connection for disabling all 4 output switches. DISABLE high overrides all other inputs. When taken low, everything functions normally. An internal pullup to V<sub>cc</sub> will keep DISABLE high if pin left open.

**PWM INPUT** - Is the TTL compatible digital input for controlling the PWM pulse width of the bridge. A duty cycle greater than 50% will produce greater than 50% duty cycle pulses out of the A out. A duty cycle less than 50% will produce greater than 50% duty cycle from the B out. For analog inputs, the integration capacitor for the internal clock must be connected between this pin and analog ground. The internal switching frequency is programmable up to 125 kHz by selection of the integration capacitor. The formula is:

$$C_F (\mu\text{F}) = \left( \frac{1.44 \times 10^7}{F_{sw}} \right) - 50$$

## **BYPASSING**

Adequate bypassing of the power supplies is required for proper operation. Failure to do so can cause erratic and low efficiency operation as well as excessive ringing at the outputs. The  $V_s$  supply should be bypassed with at least a 1 $\mu\text{F}$  ceramic capacitor in parallel with another low ESR capacitor of at least 10 $\mu\text{F}$  per amp of output current. Capacitor types rated for switching applications are the only types that should be considered. The 1 $\mu\text{F}$  ceramic capacitor must be physically connected directly to the  $V_s$  and POWER GND pins. Even one inch of lead length will cause excessive ringing at the outputs. This is due to the very fast switching times and the inductance of the lead connection. The bypassing requirements of the  $V_{cc}$  supply are less stringent, but still necessary. A .1 $\mu\text{F}$  to .47 $\mu\text{F}$  ceramic capacitor connected directly to the  $V_{cc}$  and ANALOG GND pins will suffice.

## **PCB LAYOUT**

The designer needs to appreciate that the SA60 combines in one circuit both high speed high power switching and low level analog signals. Certain layout rules of thumb must be considered when a circuit board layout is designed using the SA60:

1. Bypassing of the power supplies is critical. Capacitors must be connected directly to the power supply pins with very short lead lengths (well under 1 inch). Ceramic chip capacitors are best.
2. Connect ANALOG GND to POWER GND with a conductor having no intermediate connections. Connect all  $V_s$  power supply, filter and load related ground connections to POWER GND keeping these conductors separate until reaching pin 6. Connect all  $V_{cc}$  power supply and input signal related ground connections to ANALOG GND keeping conductors separate until reaching pin 1. Do not allow ground loops to form by making additional ground connections at the low side of the physical power supplies. If ground plane is used do not allow more than 1mA to flow through it.
3. Beware of capacitive coupling between output connections and signal inputs through the parasitic capacitance between layers in multilayer PCB designs.
4. Do not run small signal traces between the pins of the output section (pins 8-12).

## **CURRENT SENSE**

There are two load current sensing pins, I SENSE A and I SENSE B. The two pins can be shorted to POWER GND in the voltage mode connection but both must be used in the current mode connection. It is recommended that R SENSE resistors be non-inductive. Load current flows in the I SENSE pins. The SA60 has no internal current limit.

## **TRANSIENT SUPPRESSION**

An RC network of a 100 pF Capacitor and a one ohm resistor is required as shown in the external connection diagram on page 1. This network assures proper operation under various loads. Minimal power is dissipated in the resistor.

---

## CONTACTING CIRRUS LOGIC SUPPORT

For all Apex Precision Power product questions and inquiries, call toll free 800-546-2739 in North America.

For inquiries via email, please contact [apex.support@cirrus.com](mailto:apex.support@cirrus.com).

International customers can also request support by contacting their local Cirrus Logic Sales Representative.

To find the one nearest to you, go to [www.cirrus.com](http://www.cirrus.com)

---

### IMPORTANT NOTICE

Cirrus Logic, Inc. and its subsidiaries ("Cirrus") believe that the information contained in this document is accurate and reliable. However, the information is subject to change without notice and is provided "AS IS" without warranty of any kind (express or implied). Customers are advised to obtain the latest version of relevant information to verify, before placing orders, that information being relied on is current and complete. All products are sold subject to the terms and conditions of sale supplied at the time of order acknowledgment, including those pertaining to warranty, indemnification, and limitation of liability. No responsibility is assumed by Cirrus for the use of this information, including use of this information as the basis for manufacture or sale of any items, or for infringement of patents or other rights of third parties. This document is the property of Cirrus and by furnishing this information, Cirrus grants no license, express or implied under any patents, mask work rights, copyrights, trademarks, trade secrets or other intellectual property rights. Cirrus owns the copyrights associated with the information contained herein and gives consent for copies to be made of the information only for use within your organization with respect to Cirrus integrated circuits or other products of Cirrus. This consent does not extend to other copying such as copying for general distribution, advertising or promotional purposes, or for creating any work for resale.

CERTAIN APPLICATIONS USING SEMICONDUCTOR PRODUCTS MAY INVOLVE POTENTIAL RISKS OF DEATH, PERSONAL INJURY, OR SEVERE PROPERTY OR ENVIRONMENTAL DAMAGE ("CRITICAL APPLICATIONS"). CIRRUS PRODUCTS ARE NOT DESIGNED, AUTHORIZED OR WARRANTED TO BE SUITABLE FOR USE IN PRODUCTS SURGICALLY IMPLANTED INTO THE BODY, AUTOMOTIVE SAFETY OR SECURITY DEVICES, LIFE SUPPORT PRODUCTS OR OTHER CRITICAL APPLICATIONS. INCLUSION OF CIRRUS PRODUCTS IN SUCH APPLICATIONS IS UNDERSTOOD TO BE FULLY AT THE CUSTOMER'S RISK AND CIRRUS DISCLAIMS AND MAKES NO WARRANTY, EXPRESS, STATUTORY OR IMPLIED, INCLUDING THE IMPLIED WARRANTIES OF MERCHANTABILITY AND FITNESS FOR PARTICULAR PURPOSE, WITH REGARD TO ANY CIRRUS PRODUCT THAT IS USED IN SUCH A MANNER. IF THE CUSTOMER OR CUSTOMER'S CUSTOMER USES OR PERMITS THE USE OF CIRRUS PRODUCTS IN CRITICAL APPLICATIONS, CUSTOMER AGREES, BY SUCH USE, TO FULLY INDEMNIFY CIRRUS, ITS OFFICERS, DIRECTORS, EMPLOYEES, DISTRIBUTORS AND OTHER AGENTS FROM ANY AND ALL LIABILITY, INCLUDING ATTORNEYS' FEES AND COSTS, THAT MAY RESULT FROM OR ARISE IN CONNECTION WITH THESE USES.

Cirrus Logic, Cirrus, and the Cirrus Logic logo designs, Apex Precision Power, Apex and the Apex Precision Power logo designs are trademarks of Cirrus Logic, Inc. All other brand and product names in this document may be trademarks or service marks of their respective owners.

---