

8 7 6 5 4 3 2 1

E  
D  
C  
B  
A

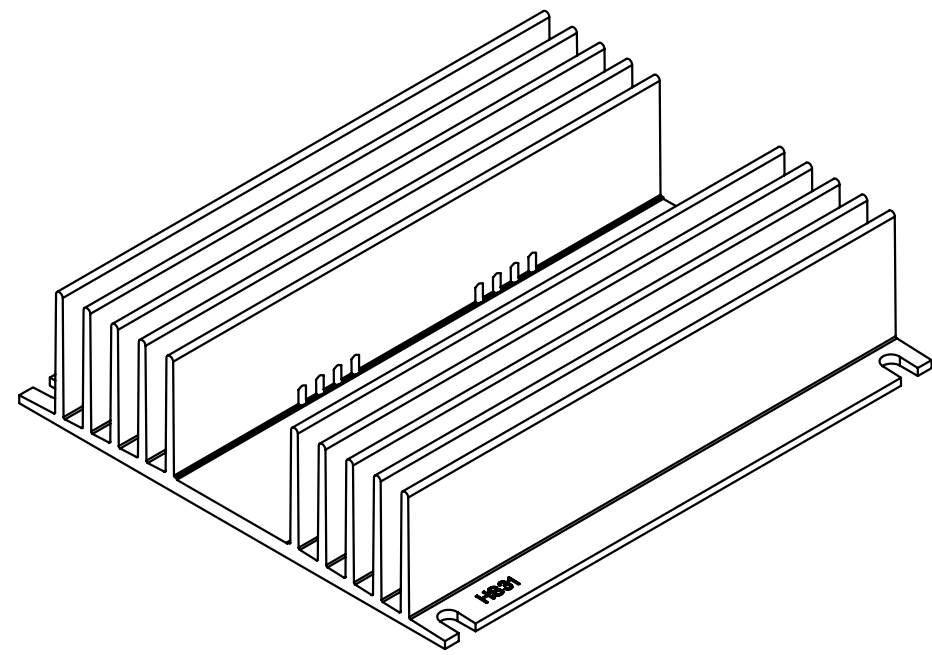
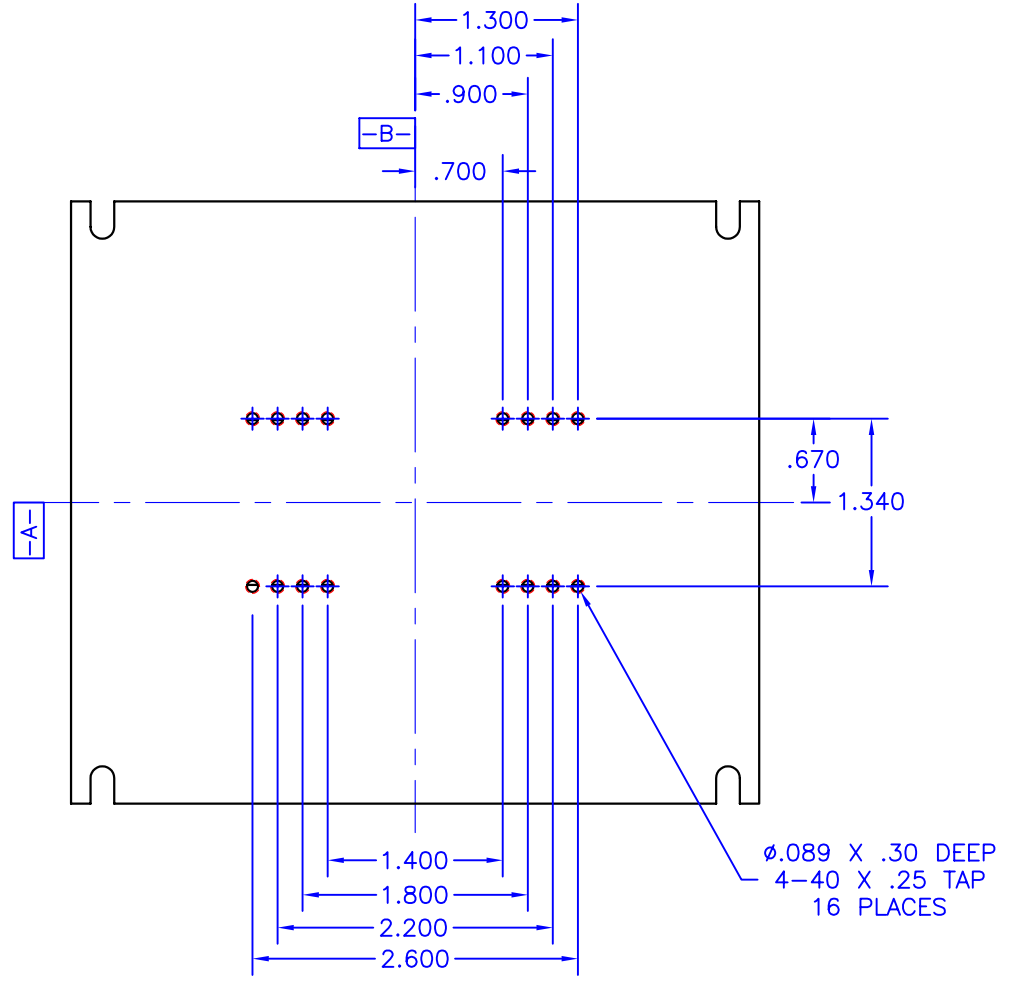
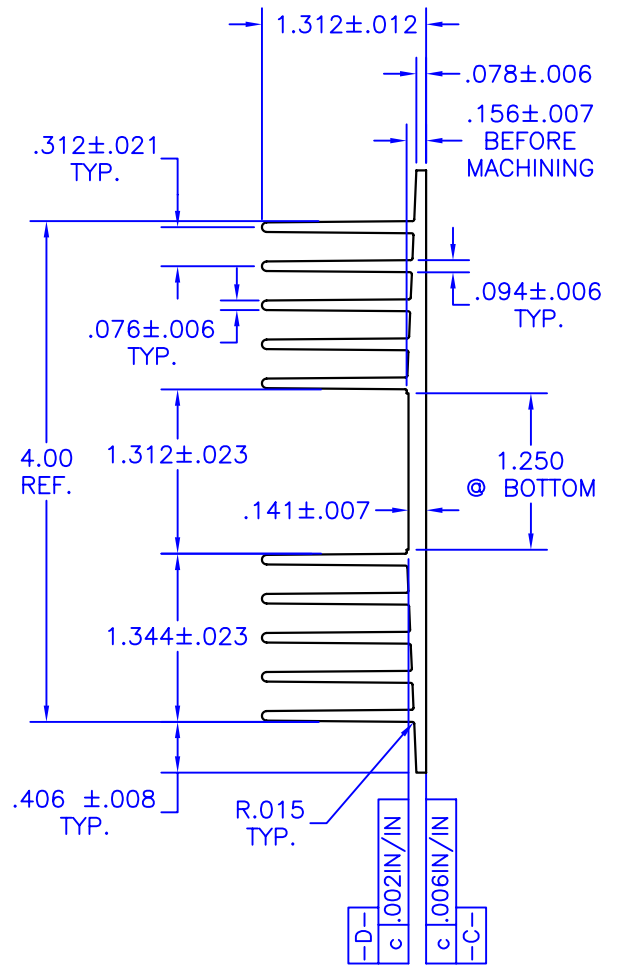
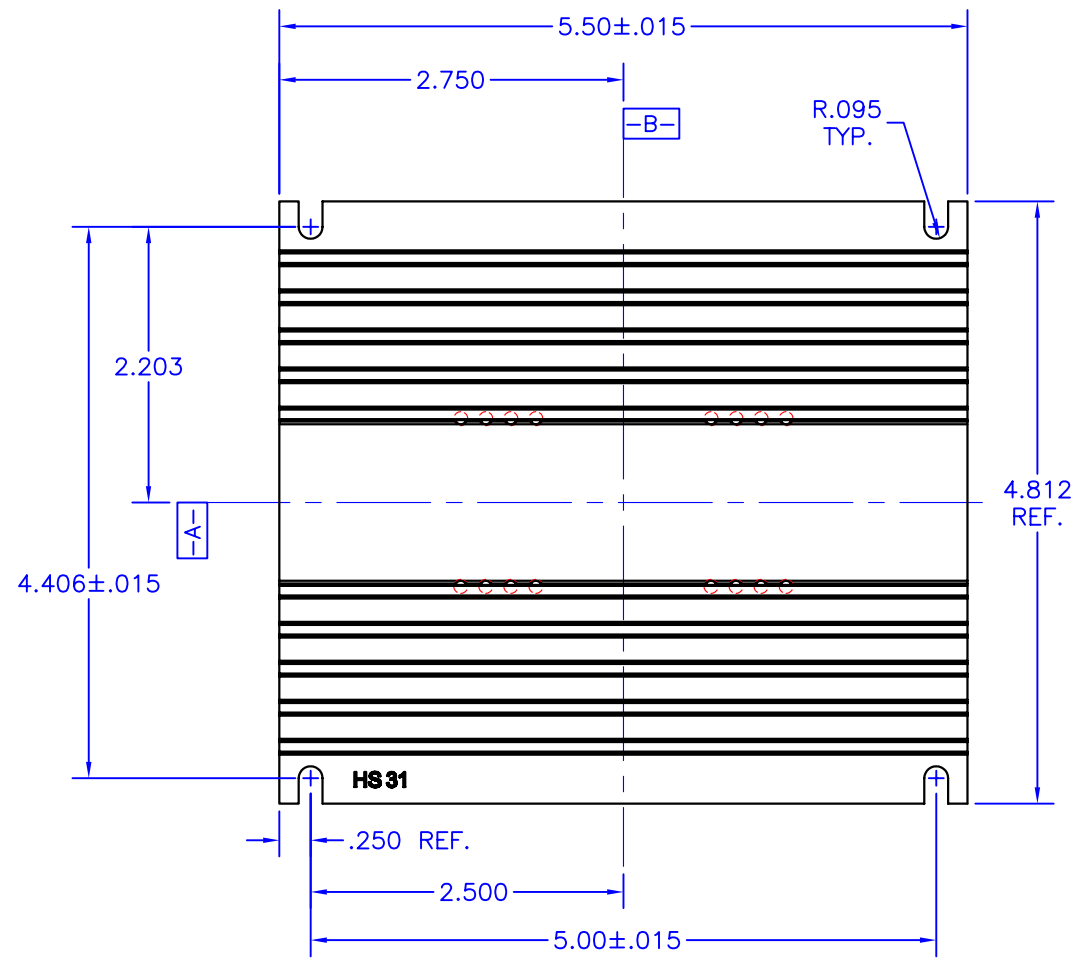

**P1 HEATSINK**  
 MAT'L: 6063-T5 ALUMINUM (AAVID EXTRUSION #60840)  
 FINISH: ANODIZE PER MIL-A-8625, TYPE II, CL 2, BLACK  
 TYPICAL BREAKDOWN VOLTAGE > 300V

- NOTES:**
- UNLESS OTHERWISE NOTED, ALL DIMENSIONS ARE IN INCHES.
  - BREAK ALL SHARP EDGES, DE-BURR & REMOVE LOOSE CHIPS.
  - MARK WITH CONTRASTING INK AS SHOWN, IF SPECIFIED BY PURCHASE ORDER.

TOLERANCES - UNLESS OTHERWISE SPECIFIED .XX = ±.01 .XXX = ±.005 ANG. = ±.5°			TITLE <b>OPEN FRAME PACKAGE HEATSINK</b>		MODEL <b>HS31</b>
SUBJECT MECHANICAL DRAWING			DATE D-M	TECH/DRN D-M	DCN 44908
		FILENAME HS31-B		REV B	DATE 07/16/04

8 7 6 5 4 3 2 1