

Proper Analog Wiring for Power Operational Amplifiers

1.0 AVOID PREDICTABLE FAILURES

This brief application note is intended to guide you through successful prototyping and final construction of power op amp circuits by using proper component location and interconnection techniques.

Proper analog construction of power op amps is just as critical as choosing the proper power op amp, heatsink, or schematic design. For reliable success, you should treat all power op amps as high frequency devices. Even though you may have designed a circuit to operate at 400Hz, the amplifier will, in general, have a bandwidth capability out to 4MHz or so and will be happy to oscillate at that frequency if not constructed properly.

In addition to this application note, be sure to read “General Operating Considerations” in the Apex Precision Power handbook for details on stability, supplies, heatsinking, mounting, current limit, SOA, and specifications interpretation.

2.0 PROPER MECHANICAL MOUNTING

Refer to Figure 1. This side view of the amplifier mounted to a heatsink shows optimum mounting to allow for wiring ease of the peripheral components associated with the power op amp. Notice the necessity of teflon sleeving to insulate the amplifier leads from the heatsink; the use of a mating socket for ease of solderable component connections; and the use of an Apex Precision Power thermal washer (or thermal grease) as the only approved interface between the amplifier and the heatsink.

You also want to be sure the recommended mounting torque of 4-7in-lbs (.45-.79 N-m) for the 8-pin TO-3 package and 8-10in-lbs (.90-1.13 N-m) for the Power Dip, JEDEC MO-127, package is used. This torque needs to be applied in small increments alternating between the two mounting bolts, similar to tightening the lug nuts on a car tire.

2.1 8-PIN TO-3 MOUNTING

Since the 8-pin TO-3 package is more sensitive to improper mounting torque, here is a rule of thumb for those who do not have ready access to a torque screwdriver:

- i) After an Apex Precision Power thermal washer or grease is applied and the teflon sleeving installed on the leads, assemble the power op amp onto the heatsink and press it firmly into the mating socket until it is firmly seated and there is no gap in the assembly.

- ii) Insert the two mounting bolts through the mounting holes in the flange of the amplifier and tighten them “finger-nail” tight. Literally use your fingernail as a screwdriver. This ensures no overtorque and gives a starting point so that the nut fits snugly against the mating socket.
- iii) After using “finger-nail” tightening, one complete revolution on the head of each mounting bolt is 4-7in-lbs. Apply this torque one quarter of a turn at a time, alternating between the two mounting bolts, until one complete revolution is reached.

3.0 PROPER ANALOG CONSTRUCTION

Figure 2 illustrates a typical inverting power op amp circuit which will be used to discuss proper component locations and wiring. Other power op amp circuits will use similar techniques.

Refer to Figure 3. This Figure shows the proper routing of connections and component locations for the circuit of Figure 2.

The mating socket will be facing towards you to allow for “unlimited” height so a “circuit ball” or “bird’s nest” of components can be soldered directly to the mating socket. This will result in an analog construction equivalent to a properly designed printed circuit board.

Note the location of all components associated with the power op amp circuit shown in Figure 2 are directly at the power op amp’s mating socket. A single point ground is illustrated by physical connection of the power supply ground, input signal ground, and output load ground.

For the single point ground wire running from the power supply to the power op amp, strip back the wire’s insulation about 2 or 3 inches and tin it with solder. This wire can then be bent or “bussed” wherever it needs to go to pick up all ground points for the power op amp and its associated components.

Stand components on end, “cordwood style”, or leave them hanging in mid-air, using the leads of the components themselves as interconnection wires.

DO NOT RUN WIRES FROM EACH PIN OF THE POWER OP AMP OVER TO A PIECE OF VECTOR BOARD, PERF BOARD, OR PRINTED CIRCUIT BOARD WHERE THE POWER OP AMP’S ASSOCIATED COMPONENTS ARE LOCATED—THIS WILL BECOME AN OSCILLATORY, ANALOG DISASTER!

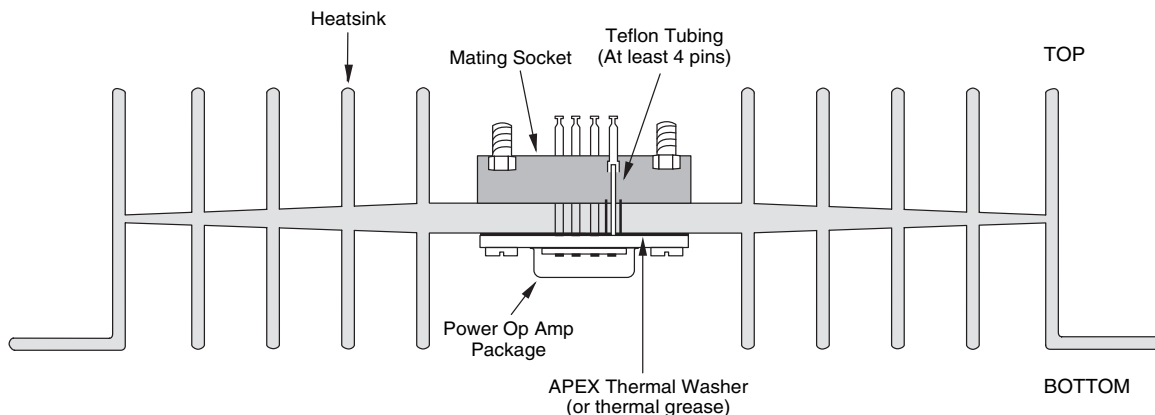

FIGURE 1. SIDE VIEW.

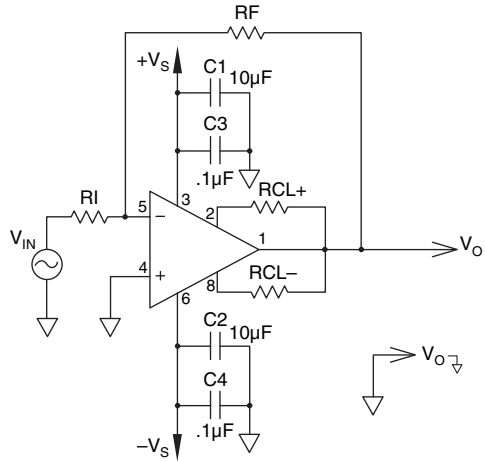

FIGURE 2. SCHEMATIC.

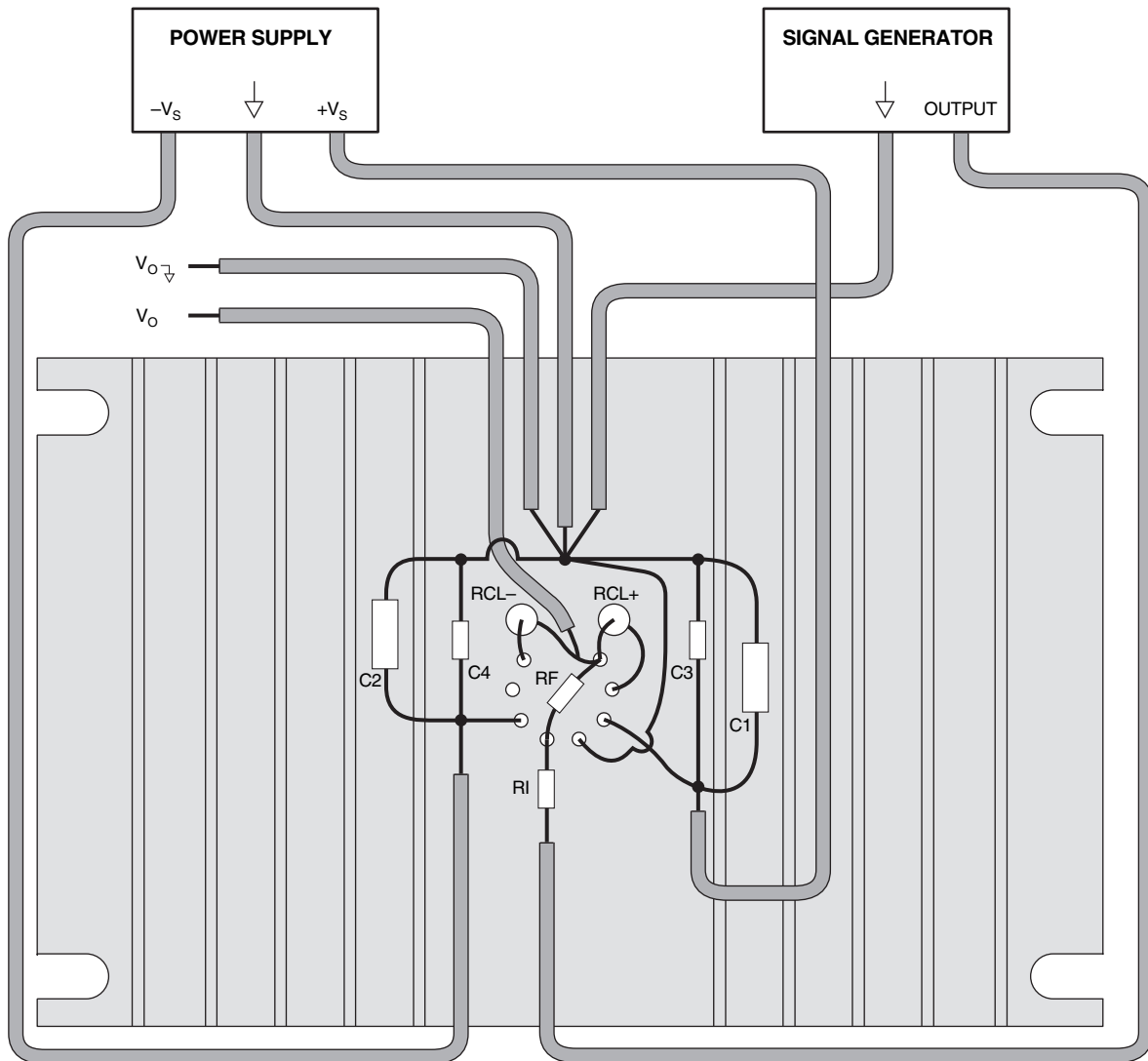

FIGURE 3. TOP VIEW. BOTTOM VIEW OF AMPLIFIER.

CONTACTING CIRRUS LOGIC SUPPORT

For all Apex Precision Power product questions and inquiries, call toll free 800-546-2739 in North America.

For inquiries via email, please contact apex.support@cirrus.com.

International customers can also request support by contacting their local Cirrus Logic Sales Representative.

To find the one nearest to you, go to www.cirrus.com

IMPORTANT NOTICE

Cirrus Logic, Inc. and its subsidiaries ("Cirrus") believe that the information contained in this document is accurate and reliable. However, the information is subject to change without notice and is provided "AS IS" without warranty of any kind (express or implied). Customers are advised to obtain the latest version of relevant information to verify, before placing orders, that information being relied on is current and complete. All products are sold subject to the terms and conditions of sale supplied at the time of order acknowledgment, including those pertaining to warranty, indemnification, and limitation of liability. No responsibility is assumed by Cirrus for the use of this information, including use of this information as the basis for manufacture or sale of any items, or for infringement of patents or other rights of third parties. This document is the property of Cirrus and by furnishing this information, Cirrus grants no license, express or implied under any patents, mask work rights, copyrights, trademarks, trade secrets or other intellectual property rights. Cirrus owns the copyrights associated with the information contained herein and gives consent for copies to be made of the information only for use within your organization with respect to Cirrus integrated circuits or other products of Cirrus. This consent does not extend to other copying such as copying for general distribution, advertising or promotional purposes, or for creating any work for resale.

CERTAIN APPLICATIONS USING SEMICONDUCTOR PRODUCTS MAY INVOLVE POTENTIAL RISKS OF DEATH, PERSONAL INJURY, OR SEVERE PROPERTY OR ENVIRONMENTAL DAMAGE ("CRITICAL APPLICATIONS"). CIRRUS PRODUCTS ARE NOT DESIGNED, AUTHORIZED OR WARRANTED TO BE SUITABLE FOR USE IN PRODUCTS SURGICALLY IMPLANTED INTO THE BODY, AUTOMOTIVE SAFETY OR SECURITY DEVICES, LIFE SUPPORT PRODUCTS OR OTHER CRITICAL APPLICATIONS. INCLUSION OF CIRRUS PRODUCTS IN SUCH APPLICATIONS IS UNDERSTOOD TO BE FULLY AT THE CUSTOMER'S RISK AND CIRRUS DISCLAIMS AND MAKES NO WARRANTY, EXPRESS, STATUTORY OR IMPLIED, INCLUDING THE IMPLIED WARRANTIES OF MERCHANTABILITY AND FITNESS FOR PARTICULAR PURPOSE, WITH REGARD TO ANY CIRRUS PRODUCT THAT IS USED IN SUCH A MANNER. IF THE CUSTOMER OR CUSTOMER'S CUSTOMER USES OR PERMITS THE USE OF CIRRUS PRODUCTS IN CRITICAL APPLICATIONS, CUSTOMER AGREES, BY SUCH USE, TO FULLY INDEMNIFY CIRRUS, ITS OFFICERS, DIRECTORS, EMPLOYEES, DISTRIBUTORS AND OTHER AGENTS FROM ANY AND ALL LIABILITY, INCLUDING ATTORNEYS' FEES AND COSTS, THAT MAY RESULT FROM OR ARISE IN CONNECTION WITH THESE USES.

Cirrus Logic, Cirrus, and the Cirrus Logic logo designs, Apex Precision Power, Apex and the Apex Precision Power logo designs are trademarks of Cirrus Logic, Inc. All other brand and product names in this document may be trademarks or service marks of their respective owners.
