

Bridge Circuit Drives

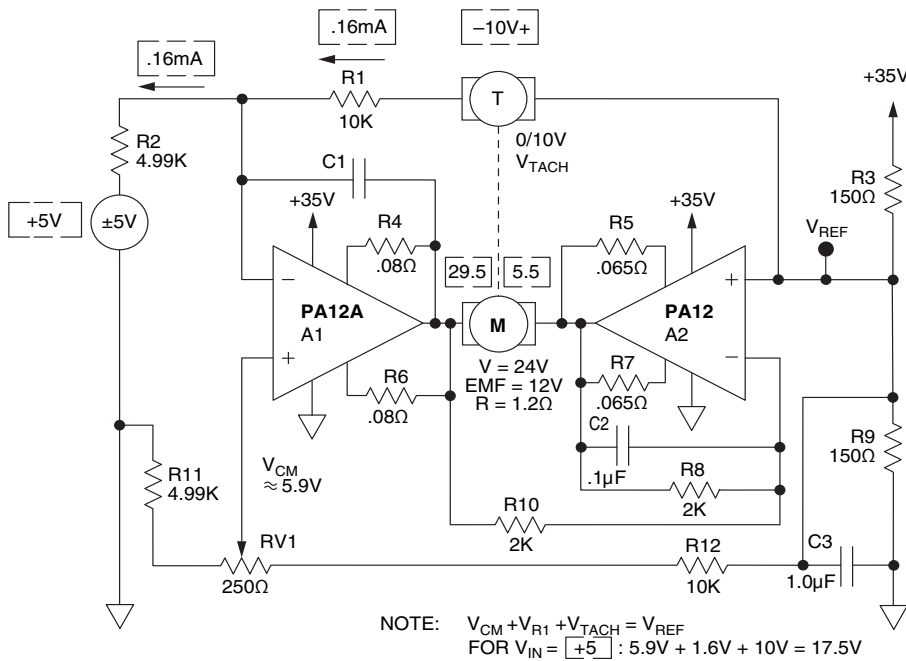

FIGURE 1. BI-DIRECTIONAL BRIDGE FOR A SINGLE SUPPLY

INTRODUCTION

Two power op amps configured in a bridge circuit can provide substantial performance advantages:

1. Bi-directional output with a single supply
2. Twice the output voltage
3. Twice the slew rate
4. Twice the output power
5. Half the power supply requirement

Low current outputs can reach the kilovolt range or multiple ampere outputs of hundreds of volts can be obtained. To achieve these levels of performance, both terminals of the load must be driven and extra components are required.

BI-DIRECTIONAL DRIVE ON A SINGLE SUPPLY

Figure 1 depicts a bi-directional motor speed control using a single supply which features ground referenced bipolar input signals. A mid-supply reference created by R3 and R9 establishes the DC operating levels for A1 and A2. Inverter A2 drives the load equally in the opposite direction with respect to the output of input amplifier A1. This configuration places both load terminals at the reference voltage with a zero input condition and prevents premature saturation of either amplifier.

To understand the operation of the circuit, consider A1 as having two sets of inputs:

1. Voltage dividers from the supply voltage to establish common mode bias.
2. Actual input signal and tachometer feedback.

One sixth of any supply voltage variation will appear equally at both inputs of the amplifier. However, the common mode rejection (CMR) of the op amp will reduce its response by four orders of magnitude at low frequencies. The low pass function

of C3 insures optimum rejection by keeping the common mode inputs in the low frequency spectrum. The common mode voltage (CMV) range of the amplifier sets the minimum common mode bias at the inputs of A1. The circuit shown provides a nominal 5.9V from the supply rail (ground) which allows power supply variations to 10% below nominal.

For the actual input signal, C1, R1, R2, and A1 form an integrator (non-inverting input is constant). With the control voltage applied across R2 and the tachometer voltage applied across R1, integration forces the motor speed to be proportional to the input voltage. The value of C1 must be selected for proper damping of the total system which includes the mechanical characteristics of the drive train.

Resistors R4 and R6 set current limits of A1 to 7.5A. When A1 current limits, A2 will reduce its output voltage equal to the voltage change of A1. By insuring A1 will limit prior to A2, power stress levels of the two amplifiers are equalized. In addition to amplifier protection, this programmability is being utilized to limit the temperature rise in the motor, thereby increasing expected life of the system. Maximum continuous load rating of the motor shown is 10A and locked rotor (stall) current is 20A. Since locked rotor ratings generally refer to abnormal conditions, the motor is being used near capacity while maintaining a comfortable safety margin for motor and drive circuit.

The key to accuracy of this circuit lies in matching the division ratios from the reference voltage to ground for both the inverting and non-inverting inputs of A1. The inverting side division ratio is affected by the impedances of the control signal and tachometer. Normally, the impedance of a voltage output DAC and the winding impedance of the tachometer are negligible. This allows use of cost effective 1% resistors and requires only trimpot RV1 to provide precision adjustment.

Ratio match errors will appear as tachometer output errors. These errors will be of a size equal to the ratio of mismatch times the reference voltage.

The second major accuracy consideration of this circuit is the voltage offset of A1. As this error will appear at the tachometer at a gain of three, the PA12A was selected for its improved specification of 3mV compared to 6mV for the regular PA12.

Changes of input voltage range, RPM range or tachometer output ratings are easily accommodated. Lowering the values of R1 and R12 (ratio match still required) will re-scale smaller tachometer voltage spans or lower RPM ranges to the $\pm 5V$ input level. While increased input signal levels could be re-scaled in the same manner, increasing R2 and R11 provides the required re-scaling with the added benefit of lowering control signal drive requirements.

Higher voltage tachometer voltage spans require a different approach to re-scaling due to the CMV limitations at the inputs of A1. Figure 2 illustrates a technique using a 25V tachometer which will maintain adequate CMV for A1 with supply voltages down to 20V. Calculations for the divide by five network at the tachometer includes winding impedance to achieve accurate scaling to the ± 5 input signal. For error budgets, this factor of five must be applied to both the ratio mismatch errors and voltage offset errors as above. Total gain for calculating offset errors will be 10.

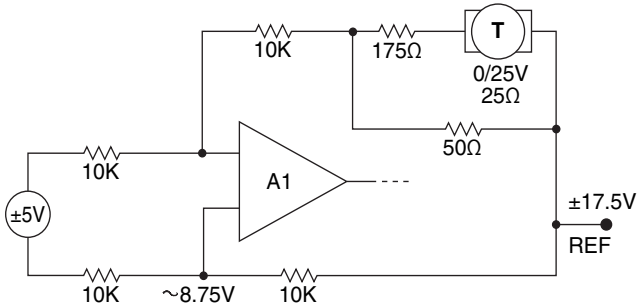

FIGURE 2. HIGH OUTPUT TACHOMETER

ELECTROSTATIC DEFLECTION

The cathode ray tube (CRT) shown in Figure 3 requires 500Vpp nominal drive. Allowing for a $\pm 5\%$ gain error plus a 10% (of full scale) centering voltage tolerance, brings the desired deflection voltage swing to 575Vpp. Two PA84 high voltage power op amps provide this differential voltage swing. Slew rates of 400 volts per microsecond at the CRT enable the beam to traverse the face plate in less than 1.5 microseconds.

The gain of A1 is set by $(R3+RV1)/R1$ at 100. The circuit provides for both gain adjustment (RV1) and beam centering (RV2). For proper scaling, R4 and R6 reduce the centering control voltage of trimpot RV2 to $\pm 250mV$. C2 provides the desired low AC impedance to ground to enhance stability and eliminate noise pickup. A2 inverts the output of A1 at unity gain (set by R8/R5), to yield an overall gain of 200 for single ended input signals measured at the differential output. R9 and C4 constitute a second input to A2 with an AC gain of 100 (R9/R8). Using ground as an input has no direct signal contribution, but it does allow both amplifiers to use the phase compensation recommended at a gain of 100 (20K, 50pF), thereby achieving a large power bandwidth of 250kHz.

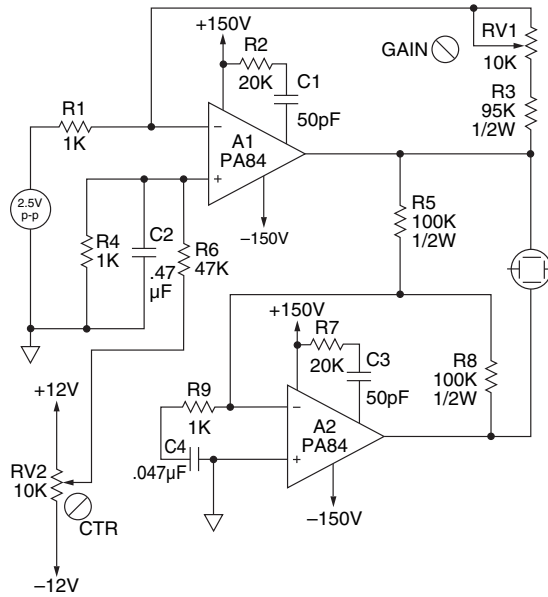

FIGURE 3. ELECTROSTATIC DEFLECTION AMPLIFIER

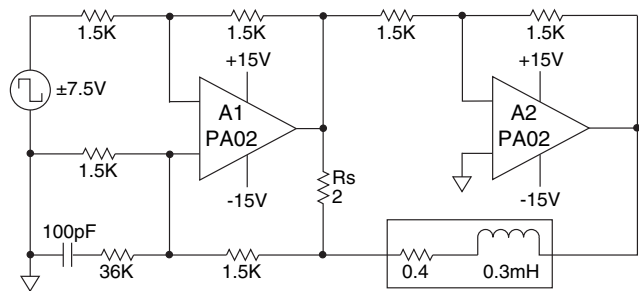

FIGURE 4. ELECTROMAGNETIC DEFLECTION AMPLIFIER

TRANSIMPEDANCE BRIDGE FOR MAGNETIC DEFLECTION

The circuit shown in Figure 4 drives the electro-magnetic deflection yoke of a precision x-y display. Two factors constitute the design challenge of this circuit:

1. Greater than 15V drive levels are required to change current magnitude and polarity to achieve fast endpoint-to-endpoint display transition times.
2. Only $\pm 15V$ power supplies are available in the system.

The bridge circuit can drive almost double the single power supply voltage, thereby eliminating the need of separate supplies solely for CRT deflection. The maximum transition time between any two points is 100μs for display ratings of:

- Yoke inductance = 0.3mH
- Full scale current = $\pm 3.75A$
- DC coil resistance = 0.4 ohms

The voltage required to change the current in an inductor is proportional to current change and inductance, but inversely proportional to transition time.

$$V = di \cdot L / dt$$

$$V = 7.5A \cdot 0.3mH / 100\mu s = 22.5V$$

The Apex Precision Power low voltage power op amp PA02 is an ideal choice for this circuit due to its high slew rate and ability to drive the load close to the supply rail. A1 in Figure 4

is configured as a Howland Current Pump. Voltage on the bottom of the sense resistor is applied directly to the load; voltage at the top is the applied voltage plus a voltage proportional to load current. With both these points for feedback, the amplifier sees a common function of load voltage on both inputs which it can reject (CMR), but sees a function of load current differentially. In this arrangement, A1 drives the load anywhere required (with in saturation limits) to achieve load current commanded by the input signal. As ratio match between the two feedback paths around A1 is critical, these four resistors are often implemented with a resistor network to achieve both precision match and tracking over temperature. A2 provides a gain of -1 to drive the opposite terminal of the coil. Gain setting resistors for A2 are not nearly as critical, a mismatch here simply means one amplifier works a little harder than the other. Starting values for the R-C compensation network come from the Apex Precision Power Power Design tool and are fine tuned with bench measurements.

A first glance, it might appear the choice of 2Ω for the sense resistor is quite large because the peak voltage drop across it is 7.5V, or half the supply voltage.

If one were to add to this the peak voltage drop across the coil resistance (1.5V) and the sense resistor (7.5V), it would be easy to assume a total swing of 31.5V or greater than 15V at 3.75A would be required of each amplifier.

Salvation for this problem lies in analyzing current flow direction.

In the middle graph of Figure 5, we find the large sense resistor does not destroy the circuit drive capability. The main portion of the transition is complete in about 80μs and settles nicely.

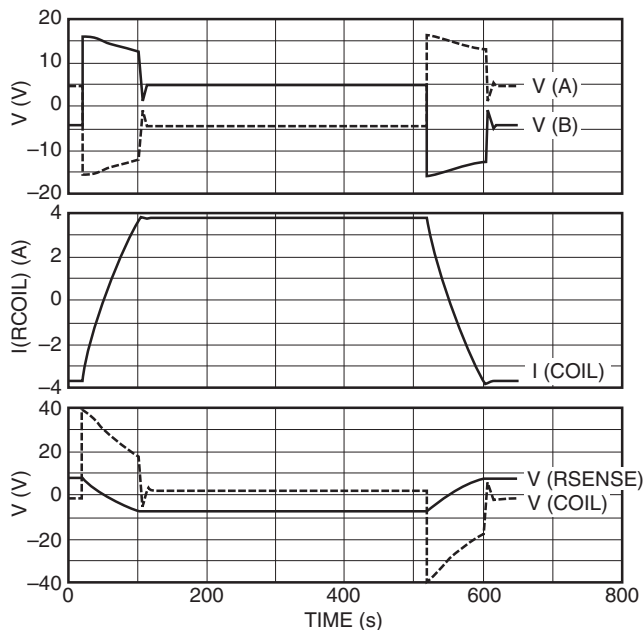

FIGURE 5. MAGNETIC DEFLECTION VOLTAGE AND CURRENT WAVEFORMS

In the top graph, we find a surprise; both amplifiers are actually swinging OUTSIDE their supply rails. The "upside down" topology of the output transistors in the PA02 allows energy stored in the inductor to fly back, turning on the internal protection diodes. The result is peak voltages in the first portion of the transition greater than total supply.

In the bottom graph, we find stored energy in the inductor

develops voltage across the sense resistor, which ADDS to the op amp voltage until current crosses zero. In this manner, peak voltage across the coil is nearly 40V!

The seemingly large value of sense resistor did not kill us on voltage drive requirements and gives two benefits: First, internal power dissipation is lower than with a smaller resistor. Secondly, with larger feedback signal levels, the amplifier closed loop gain is lower; loop gain is larger; fidelity of the current output is better; and voltage offset contributes a lower current offset error.

EFFICIENT USE OF POWER SUPPLIES

To illustrate the advantages of the bridge circuit, Figures 6 and 7 show two high performance audio amplifier designs with equal output power, but substantially different supply requirements. In the circuit of Figure 6, the instantaneous load current will appear on only one supply rail. This means each supply rail must support the total wattage requirement and utilization is only 50% at peak outputs. In contrast, the equal and opposite drive characteristic of the bridge circuit shown in Figure 7 loads both positive and negative supply rails equally during each half cycle of the signal. This improved utilization reduces size, weight and cost of the power supply for the circuit in Figure 7 even though input and output power ratings are essentially equal.

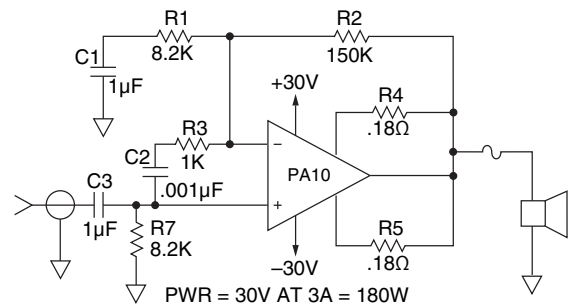

FIGURE 6. STANDARD AUDIO AMPLIFIER

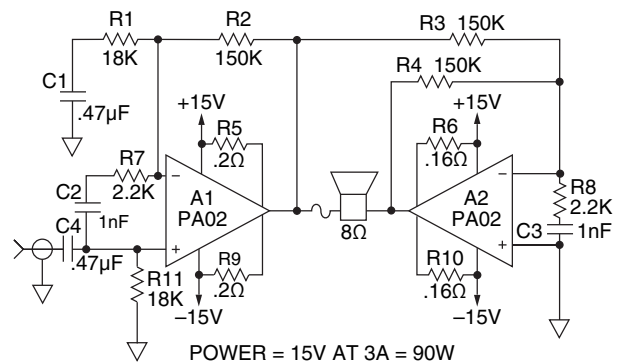

FIGURE 7. BRIDGE AUDIO AMPLIFIER

CONCLUSION

Bridge circuits can make the difference when performance requirements exceed voltage limitations of either the available power supplies or the power op amps. The input section of these circuits consists of a standard amplifier circuit for driving a single ended load. The added amplifier serves merely as an inverter. It doubles drive voltage by providing an equal and opposite output, thereby making the output fully differential. The performance increases usually outweigh the increased cost and complexity.

CONTACTING CIRRUS LOGIC SUPPORT

For all Apex Precision Power product questions and inquiries, call toll free 800-546-2739 in North America.

For inquiries via email, please contact apex.support@cirrus.com.

International customers can also request support by contacting their local Cirrus Logic Sales Representative.

To find the one nearest to you, go to www.cirrus.com

IMPORTANT NOTICE

Cirrus Logic, Inc. and its subsidiaries ("Cirrus") believe that the information contained in this document is accurate and reliable. However, the information is subject to change without notice and is provided "AS IS" without warranty of any kind (express or implied). Customers are advised to obtain the latest version of relevant information to verify, before placing orders, that information being relied on is current and complete. All products are sold subject to the terms and conditions of sale supplied at the time of order acknowledgment, including those pertaining to warranty, indemnification, and limitation of liability. No responsibility is assumed by Cirrus for the use of this information, including use of this information as the basis for manufacture or sale of any items, or for infringement of patents or other rights of third parties. This document is the property of Cirrus and by furnishing this information, Cirrus grants no license, express or implied under any patents, mask work rights, copyrights, trademarks, trade secrets or other intellectual property rights. Cirrus owns the copyrights associated with the information contained herein and gives consent for copies to be made of the information only for use within your organization with respect to Cirrus integrated circuits or other products of Cirrus. This consent does not extend to other copying such as copying for general distribution, advertising or promotional purposes, or for creating any work for resale.

CERTAIN APPLICATIONS USING SEMICONDUCTOR PRODUCTS MAY INVOLVE POTENTIAL RISKS OF DEATH, PERSONAL INJURY, OR SEVERE PROPERTY OR ENVIRONMENTAL DAMAGE ("CRITICAL APPLICATIONS"). CIRRUS PRODUCTS ARE NOT DESIGNED, AUTHORIZED OR WARRANTED TO BE SUITABLE FOR USE IN PRODUCTS SURGICALLY IMPLANTED INTO THE BODY, AUTOMOTIVE SAFETY OR SECURITY DEVICES, LIFE SUPPORT PRODUCTS OR OTHER CRITICAL APPLICATIONS. INCLUSION OF CIRRUS PRODUCTS IN SUCH APPLICATIONS IS UNDERSTOOD TO BE FULLY AT THE CUSTOMER'S RISK AND CIRRUS DISCLAIMS AND MAKES NO WARRANTY, EXPRESS, STATUTORY OR IMPLIED, INCLUDING THE IMPLIED WARRANTIES OF MERCHANTABILITY AND FITNESS FOR PARTICULAR PURPOSE, WITH REGARD TO ANY CIRRUS PRODUCT THAT IS USED IN SUCH A MANNER. IF THE CUSTOMER OR CUSTOMER'S CUSTOMER USES OR PERMITS THE USE OF CIRRUS PRODUCTS IN CRITICAL APPLICATIONS, CUSTOMER AGREES, BY SUCH USE, TO FULLY INDEMNIFY CIRRUS, ITS OFFICERS, DIRECTORS, EMPLOYEES, DISTRIBUTORS AND OTHER AGENTS FROM ANY AND ALL LIABILITY, INCLUDING ATTORNEYS' FEES AND COSTS, THAT MAY RESULT FROM OR ARISE IN CONNECTION WITH THESE USES.

Cirrus Logic, Cirrus, and the Cirrus Logic logo designs, Apex Precision Power, Apex and the Apex Precision Power logo designs are trademarks of Cirrus Logic, Inc. All other brand and product names in this document may be trademarks or service marks of their respective owners.
