

Unleashing the Audio Potential of Smartphones:

DEDICATED AUDIO ICs LIKE SMART AUDIO CODECS AND HYBRID CLASS-D AMPLIFIERS CAN HELP SOLVE SYSTEM-LEVEL CHALLENGES, OFFERING MOBILE USERS INCREASED AUDIO PERFORMANCE AND BATTERY LIFE

By Rob Kratsas, Marketing Manager, Mixed Signal Audio Products, Cirrus Logic

Smartphones are one of hottest trends in consumer electronics. According to the Federal Communications Commission, their use has increased 700 percent over the past four years. And it's no surprise why. Combining the functions of a personal computer (PC), mobile phone, personal media player and recorder in a single device, consumers are using them to organize data, manage e-mail, access the Internet, listen to music, play games, take and view still photos and videos, handle voice calls, and even navigate their way around.

All of this is placing greater demands on the smartphone hardware, which is being asked to deliver ever increasing performance while at the same time keeping power consumption to a minimum, even as consumers expect longer battery life from their devices. These demands will only increase as the industry moves from current 3G to 4G networks.

With faster data rates, and with mobile data projected to increase at a rate of 130 percent annually, consumers will migrate to using their smartphones for more media-rich applications. As consumers spend more time using their devices as multimedia platforms, they will expect higher-quality audio and video performance as well as a battery life that accommodates these longer use times.

CIRRUS LOGIC, INC.

2901 Via Fortuna
Austin, Texas 78746
United States

T +1-512-851-4000

F +1-512-851-4977

Toll-Free +1-800-888-5016

SALES SUPPORT

North America +1 800-625-4084

Asia Pacific +852 2376-0801

Japan +81 (3) 5226-7757

Europe/UK +44 (90) 1628-891-300

LEARN MORE AT

www.cirrus.com



APPLICATION PROCESSOR

Typically, it's the smartphone's application processor that is being asked to handle more of these multimedia functions. This is in addition to its primary role of providing the smartphone's main functionality, which includes running the phone's operating system, user interface and applications. The application processor must do all these tasks efficiently, providing the additional processing capabilities while still using minimal power consumption.

To meet these increasing needs, many smartphones are using 500 MHz or better mobile processors, while off-loading tasks such as audio/video decoding to a separate dedicated processor(s). The dedicated processor is able to perform the certain functions more efficiently, offering better performance at lower power, than can be done on the main processor.

Similarly, off-loading audio functions to a dedicated audio subsystem can offer improved audio performance and more efficient power management, as well as ease of design. This often includes integrating audio signal processing as well, which further optimizes power consumption by moving these function off the apps processor—which is critical as end users increasingly spend more time playing back higher-resolution audio and video on their smartphones.

AUDIO SOURCES IN SMARTPHONES

A number of audio sources exist in today's smartphones. Speakers, headphones, and headsets pump out voice data from the phone and compressed audio files from the built-in music player. Many smartphones have voice recorders to take notes, and some have built-in GPS systems that provide voice commands to give directions.

As smartphones increase in functionality, the number of audio functions will increase. Smartphones are being asked to provide levels of audio quality far exceeding that of conventional phones, particularly as software applications proliferate for various business productivity and personal entertainment tasks.

Smartphones are increasingly required to provide dynamic ranges around 95dB for the audio playback path and incorporate features such as multi-band equalizers, 3-D surround effects, audio enhancement and echo/noise cancellation. Such demands are dictating the need for audio components able to process signals with fewer losses at higher frequencies, and with lower power consumption than existing audio components.

AUDIO CHALLENGES

The myriad of audio inputs, outputs, and corresponding use cases on smartphones present many challenges for the system designer. These include complex mixing and routing of various mono and stereo audio signals (in analog or digital formats) to and from speakers, microphones, and headphones, as well as the recording and playing back of content in a wide variety of digital audio formats with various bit depths and sample rates.

In most smartphones, audio functionality must be able to accommodate at a minimum two input microphones (one internal and one external headset) and several speaker outputs (internal stereo and external headset), as well as possible additional transducers depending on the phone design or desire for extra functionality (e.g., noise cancellation, hands-free use etc.).

In addition to handling traditional voice telephony communication and its typical 8 kHz sample rate, today's phones are expected to be able to play back multimedia files like videos, music MP3s and ringtones, as well as streaming audio from online sources, which means being able to accommodate a variety of other sample rates.

Many of these functions must be accomplished simultaneously - such as a user playing a music file while talking on a headset - so that the appropriate audio signal is synchronized and routed to the proper output destination, all with minimal processing and power consumption.

AUDIO ICs IN MOBILE COMMUNICATIONS

To perform the wide range of audio functions, smartphones incorporate a number of audio ICs. Typically, a Class D or Class AB amplifier is used to drive the hands-free speakers and a Class AB or Class H amplifier is used to drive the headphones.

These devices, along with, specialized audio processors, ADCs, DACs, and baseband processors handle a wide range of audio functions including fielding voice calls, playing and recording music, playing sound effects, providing sound for GPS and, in some smartphones, recognizing and synthesizing speech.

The choice of amplifiers is crucial to smartphone performance. Class G amplifiers use rail switching to reduce power consumption and are more efficient than standard Class AB amplifiers, but less efficient than Class D. Class H takes the idea of Class G a step further by modulating the supply rails in a continuous fashion, so that the rails are only slightly larger than the output signal at any given time. Class H also has the added advantage of providing the discrete power levels from a single power supply by using an inverting step down charge pump. This eliminates the need to have multiple power supplies to drive the audio headphone amplifier.

Because of their higher efficiency compared to Class AB, Class D amplifiers have been used widely for home theater system and automotive subwoofers. But issues such as output filter design and management of switching noise present challenges for their implementation in mobile applications.

Audio subsystems used in smartphones combine headphone amplifiers with speaker amplifiers on a single chip. They typically incorporate a Class D amplifier to drive speakers and a Class AB, D, or G amplifier to drive the headphones.

An alternative to an audio subsystem is a codec, which integrates a range of functions in a single device including amplifier technology as described above, high quality audio data conversion and signal processing. In some applications, codecs may include parametric equalizers, sound mixers, dynamic range control, noise cancellation or noise suppression, 3D sound processing, and various audio interfaces. Some available audio codecs with appropriate mixing and sample rate conversion functionality integrated, allow the application processor to be bypassed and have audio sources such as the baseband processor, Bluetooth receiver or FM tuner, directly connect to the codec thus reducing the processing burden and power consumption of the application processor.

Highly integrated audio devices incorporating multiple inputs/outputs and functions like sample rate conversion make it possible for designers to reduce the need for additional components to implement audio functions in smartphones.

OFF-LOADING AUDIO FUNCTIONS

Audio subsystems and codecs are helping designers get around the design and performance trade-offs resulting from implementing all the audio functions in integrated phone chipsets. For one, there is the issue of isolating various audio parts residing close together in the same package. Moreover, integrating all the audio into phone chipsets makes it more difficult to properly implement power management, which is crucial if power consumption is to be minimized in the smartphone.

To compensate for the mediocre performance with current audio components, smartphone makers have relocated audio functions out of the main mobile phone chipsets to improve isolation and improve signal performance. By implementing audio externally, designers can use chips with different process technologies, freeing them from being encumbered by the other's process technologies. Off-loading the audio functions out of the main processor has freed audio/power management IC engineers to reintegrate various functions into stand-alone amps with power management, audio amp subsystems, and sophisticated audio codec systems.

Off-loading audio functions to a dedicated audio subsystem can offer improved audio performance, better efficiency, as well as ease of design. This often includes integrating limited power management functions such as LDOs for direct connection to the battery, or charge pumps to allow on board boost voltages to support unique amplifiers, which further optimizes power consumption – which is critical as end users increasingly spend more time playing back high-resolution audio and video on their smartphones.

CIRRUS LOGIC IN THE AUDIO IC MARKET

As a leading supplier of signal processing components, Cirrus Logic has been delivering innovative products to a variety of consumer, professional, and automotive digital audio applications for over 20 years, including A/D and D/A converters, codecs, digital signal processors, digital audio interfaces, volume control ICs, and digital amplifiers. Recently, Cirrus Logic has introduced many products for portable consumer applications and is now bringing that same innovative technology to products specifically targeting the mobile communications market. These new smartphone audio products aim to maximize audio performance and quality while minimizing power consumption and complexity associated with end product design.

Cirrus Logic has raised the bar on low power codecs. The company's first-generation codecs occupied 65 percent less space and reduced bill of materials costs by 20 percent over its competitors. Cirrus' second-generation codecs were 60 percent smaller than the first generation and extended battery life by two hours, consuming 50 percent less power than the competitive state of the art at the time.

For the third generation, Cirrus has developed a codec that, based on the complexity of smartphones, offers nearly twice the functionality found in the second generation while lowering power consumption 40 percent and overall size by 30 percent. One of the drivers for lowering power consumption so much is an improvement to Cirrus' proprietary ground-centered Class H headphone amplifier IP. Combined with an ultra small, high performance D/A converter, Cirrus' newest smarter audio codec enables best-in-class stereo playback power consumption of only 3.5-mW.

Cirrus has also developed a family of Class D speaker amplifiers that address the need to provide more power to speakerphones without driving power consumption up and also minimize the impact of electromagnetic interference (EMI) issues for the overall system design.

HIGH-PERFORMANCE AMPLIFIERS

To meet the multiple challenges of delivering high-quality audio from a mobile handset while keeping noise and power consumption low, Cirrus Logic has developed an amplifier designed for an emerging generation of full-function smartphones. The result is the CS35L01 (6 dB gain) and CS35L03 (12 dB gain) hybrid Class D audio amplifiers, which combine Class D efficiency and output power with Class-AB-like low idle current consumption and minimal EMI.

The CS35L01/03 extends smartphone battery life by offering a quiescent current of only 0.9 mA – 50 percent less than that the competing parts. In addition, the hybrid Class D architecture allows designers to optimize their system performance with external components if needed, such as with an external shunt cap without sacrificing significant power consumption when idle.

A unique feature of the amplifiers is their flexible hybrid Class D output stage that enables four configurable modes of operation:

Standard Class D (SD) mode supports full audio bandwidth with optimal analog performance. This mode of operation is characterized by a traditional closed loop, analog modulated Class D amplifier. With an output switching frequency of 192 kHz, this mode ensures flat frequency response across the entire audio frequency range.

Reduced Frequency Class D (FSD) mode provides competitive analog performance and a reduction in radiated emissions by decreasing the switching frequency to 76 kHz. This reduction in switching frequency reduces the high-frequency energy being created by the output switching events, which in turns reduces EMI and power consumption.

Hybrid Class D (HD) mode provides competitive analog performance with a substantial reduction in idle power dissipation and radiated emissions. In this mode, the output switches at 192 kHz and a lower voltage supply is derived from the battery supply using an internal low drop-out linear regulator (LDO). When the input signal is at a low amplitude or at idle, the Class D output stage begins to switch from the lower rail voltage which decreases power consumption and EMI by reducing the amplitude of the square waves being created at the output of the amplifier.

Reduced Frequency Hybrid Class D (FHD) mode provides the best overall EMI performance and the lowest power consumption with slightly decreased frequency response near the top frequency range of the audio band. Combining hybrid Class D design and changing of the switching frequencies dynamically according to the input signal, the resultant reduction in switching energy dramatically reduces the emissions levels of the output stage and its associated components.

With 4 modes of operation, the CS35L01 and CS35L03 allow designers the flexibility to optimize system performance with ease and significantly reduce design-to-market time. In addition, the hybrid Class D architecture allows designers to further reduce radiated emission with external components if needed, such as with an external shunt cap, without sacrificing significant power consumption when idle.

Quiescent Current Comparison

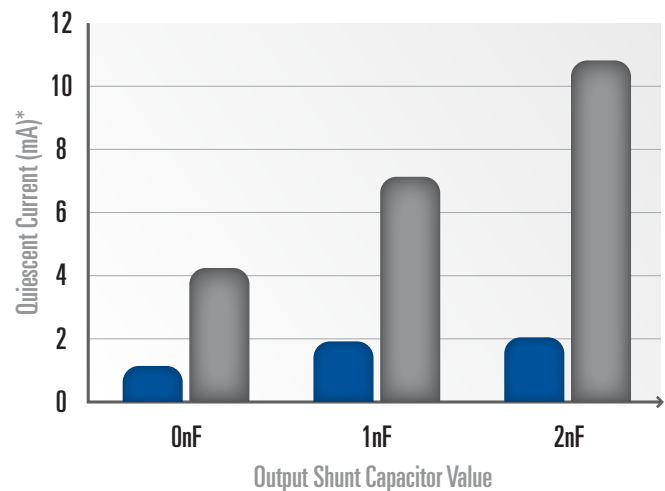

The amplifier's Delta Sigma closed-loop architecture provides a power supply rejection ratio of -85 db at 217 Hz. THD+N is 0.02 percent at 1 W.

Internal thermal overload protection, using on-board temperature sensing circuitry, monitors die temperature and places the device into shutdown if thermal overload occurs. The CS35L01 and CS35L03 are available in a 9-ball WLCSP package in a commercial grade rated for operating temperatures of -10°C to +70°C.

SMART AUDIO CODEC

Focused on solving the increasing complex audio usage cases? in smartphones, Cirrus Logic's CS42L73 smart audio codec features best-in-class power consumption along with a digital mixer and high-performance asynchronous sample rate converters to ensure that designers can incorporate the full range of audio functions that consumers expect.

The codec's rated power consumption is 6.4 mW at 1.8 V during a handset voice call using an analog microphone or 4.1mW when using digital microphones, offering the lowest power consumption in the market for products with asynchronous sample rate converters and a digital mixing engine. Power consumption is even lower when playing back stereo audio. The low power consumption will enable smartphone designers to incorporate robust multimedia features into their devices and allow consumers to fully experience their phone's features, while still enjoying extended battery life.

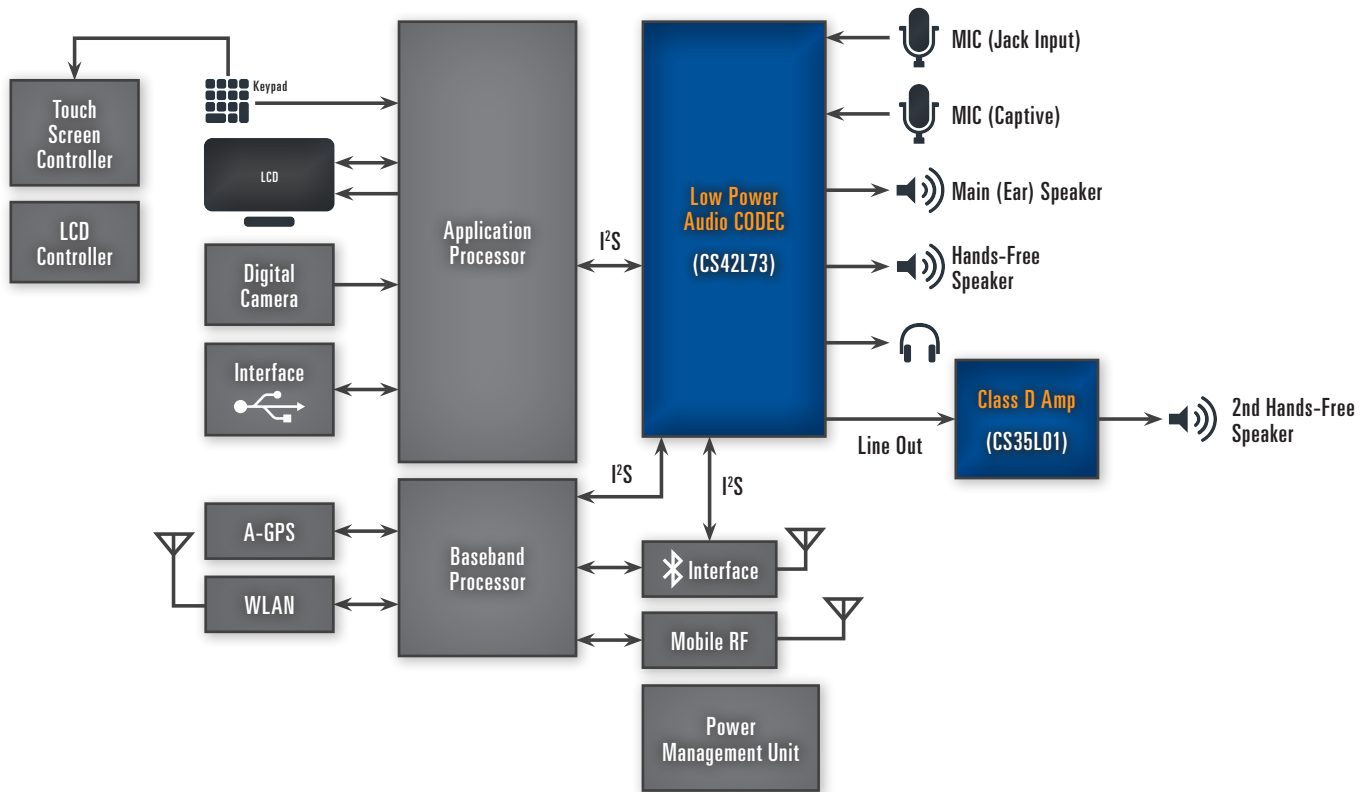

Figure 1: A block-level diagram of the CS42L73 smart audio codec.

The codec's digital mixer provides digital audio routing with independent mixer input attenuation control, and uses asynchronous sample rate converters (ASRCs) to bridge potentially different rates at the serial ports inputs as well as within the digital processing core. It mixes and routes the codec's inputs (analog inputs to ADC, digital MIC, or serial port) to outputs (DAC fed amplifiers or serial ports).

There is independent attenuation on each mixer input. All routes from inputs to outputs are supported, and all paths have selectable attenuation before being mixed to allow relative volume control and to avoid clipping.

To handle voice and audio data, the CS42L73 has three independent, highly configurable serial ports to transmit data to and from other system devices including application processors, Bluetooth transceivers, and cell phone modems. They are the auxiliary, audio, and voice serial ports (XSP, ASP, and VSP). The XSP and ASP ports have separate power-down controls for their input and output data paths.

The CS42L73 uses two stereo ASRCs for the XSP and ASP paths, one mono ASRC is used for the VSP input path, and three stereo ASRCs are used for the XSP, ASP, and VSP output paths. The digital processing side of the ASRCs connect to the digital mixer, with the added advantage of utilizing a Cirrus proprietary filter architecture that minimizes latency during a phone call.

The codec is based on a 0.18-micron converter core comprising a stereo ADC and two stereo DACs. The converters provide the high signal fidelity needed to implement advanced smartphone audio functions. The ADC exhibits a signal-to-noise ratio of 91 dB and a THD+N of -85 dB at 1.8 V. The DACs have a dynamic range of 94 to 97 dB and a THD+N of -81 to -86 dB at 1.8 V. Both converters operate at a low oversampling ratio of 64x F_s , maximizing power savings while maintaining high performance.

The codec can implement a number of smartphone audio functions through its analog outputs, which include Class H controlled ground centered drivers, a Class AB mono hands-free speaker driver, a speaker line-output for stereo expansion, and a mono ear receiver speaker. The codec's analog output portion includes separate pseudo-differential headphone and line out Class H amplifiers. The codec's on-board step down inverting charge pump architecture eliminates the need for large DC-blocking capacitors and allows the amplifier to deliver more power to headphone loads at lower supply voltages. This charge pump architecture has the lowest DC offset of any headphone amplifier integrated on an audio codec. Combined, the ground centered outputs with low DC offset provide better overall audio frequency response and minimize audible pops and clicks during power cycling and other audio source switching.

The codec's analog inputs include a stereo line or mic, 2:1 stereo mux, ALC & PGA, and dual independent, low-noise mic bias outputs. Digital interfaces include a dual digital microphone interface, and of course three audio serial ports with ASRCs.

The high functionality and performance of the CS42L73 combines with a small package size suited for today's smartphones. The code is available in a 64-ball (3.44 x 3.44 mm) wide-lead chip-scale package with a 0.4-mm pitch. It is also available in a 65-ball (5 x 5 mm) FBGA with a 0.5-mm pitch. The package occupies 50 percent less space than comparably featured competitive parts.

SUMMARY

With the introduction of the CS35L00, CS35L01, CS35L03 amplifiers and CS42L73 audio codec, Cirrus Logic has developed robust solutions designed to address the future market for high-end smartphones. Together, the CS35L0x and CS42L73 address multiple system-level challenges facing smartphone designers.

The amplifier's low power consumption and superior EMI performance will enable the smartphone to conserve battery life and preserve high signal fidelity, while the codec's comprehensive feature set and intelligent functions will alleviate much of the audio processing burden saddling the main processors in smartphones.

The combination of the amplifier and codec will enable smartphone makers to incorporate robust audio functions in their devices. With lower power consumption and higher analog performance, smartphone makers will be able to create products that will make audio a feature that differentiates the mobile phone to the consumer.

This new generation of high-performance audio parts are designed to enable engineers to address the multiple design and performance challenges of implementing audio functions in the next generation of smartphones. These products represent a harbinger of things to come from Cirrus Logic, offering some insight into a roadmap to future devices that will enable consumers to reap the full benefits of the smartphone's rich blend of multimedia features.

