

Evaluation Kit for SA12 PWM Amplifier

INTRODUCTION

This easy-to-use kit provides a platform for the evaluation of PWM amplifiers using the SA12 pin-out configuration. It can be used to analyze a multitude of standard or proprietary circuit configurations, and is flexible enough to do most standard amplifier test configurations.

The schematic is shown in Figure 3. Note that all of the components shown on the schematic will probably not be used for any single circuit. Some components will simply be omitted, while others require installation of a jumper to complete the signal path.

Only components unique to the EK17 are provided in this kit. Hardware similar to that shown in Figure 1 must be obtained locally.

BEFORE YOU GET STARTED

- * All Apex Precision Power amplifiers should be handled using proper ESD precautions.
- * Always use the heatsink included in this kit with TW05 washer.
- * Always use adequate power supply bypassing.
- * Do not change connections while the circuit is powered.
- * Initially set all power supplies to the minimum operating allowed in the device data sheet.

PARTS LIST

Apex Part #	Description	Quantity
HS18	Heatsink	1
MS04	PC mount Cage Jacks	1 Bag/12 each
EVAL19	PC Board	1
60SPG00001	Spacer Grommets	4
TW05	Thermal Washer	1 Box/10 each
OX7R105KWN	1µF Cap 1825B105K201N, Novacap	3
TS01	Terminal Strip 66505 Beau Interconnect	1
EC03	680 µF Cap United Chemi-Con KMH200VN68IM25X40T2	1
HS22	Heatsink Thermolly 6025B	2
CSR03	0.01 ohm resistor Caddock MP916-0.010 - 5%	2
CSR04	0.020 ohm resistor Caddock MP930-0.020 - 5%	2

FIGURE 1.

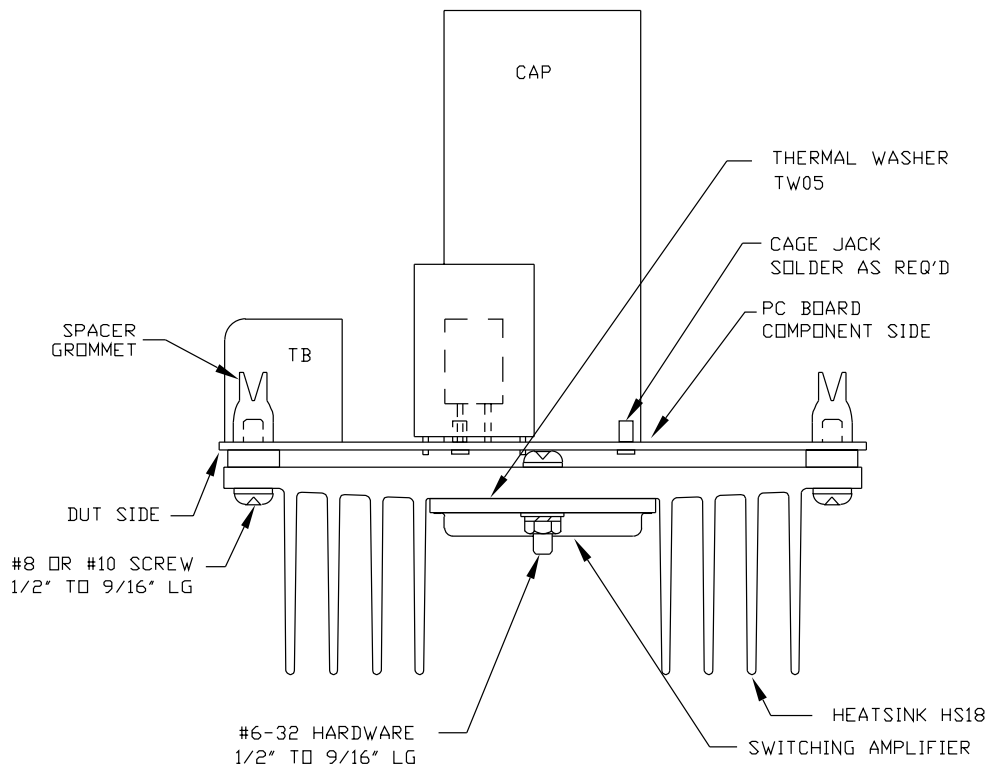

ASSEMBLY

During assembly refer to Figures 1 & 2

1. From the DUT of the PCB insert and solder the 12 cage jacks. Also solder the cage jacks from the circuit side as well, making sure the cage jack remains flush with the component side of the PCB.
2. Solder the 3 surface mount ceramic capacitors to the component side of the PCB.
3. From the component side of the PCB insert the terminal strip. Solder from the circuit side of the PCB. Be sure that the GND terminal hole in the PCB is fully filled with solder.
4. Two values of current limiting power resistors are supplied. Select one value (see the amplifier data sheet to learn how to calculate which resistor will suit your need). Coat the backside of the power resistor with heat sink compound (not supplied). Using 4-40 screws and nuts (not supplied) mount the resistors to the two small heat sinks supplied. Solder the resistor/heat sink assembly to the component side of the PCB.
5. Insert the electrolytic capacitor into the PCB from the component side and solder from the circuit side making sure to fill the mounting holes with solder.
6. From the circuit side, push spacer grommets into PCB until fully seated. Grommets will snug when screws are inserted for heatsink mounting.
7. Apply TW05 thermal washer to the bottom of the amplifier.
8. Use #14 sleeving to insulate and align at least 2 opposite pins of the amplifier.
9. Mount amplifier to heatsink using #6 screws and nuts. Torque the part to the specified 8 to 10 in-lbs (.9 to 1.13 N*M). Do not over torque.
10. Install components as needed. External connections may be soldered directly or standard banana jacks may be soldered to the large pads at the edge of the PCB.
11. Insert amplifier pins into cage jacks and fasten PCB to heatsink.

FIGURE 2. PCB

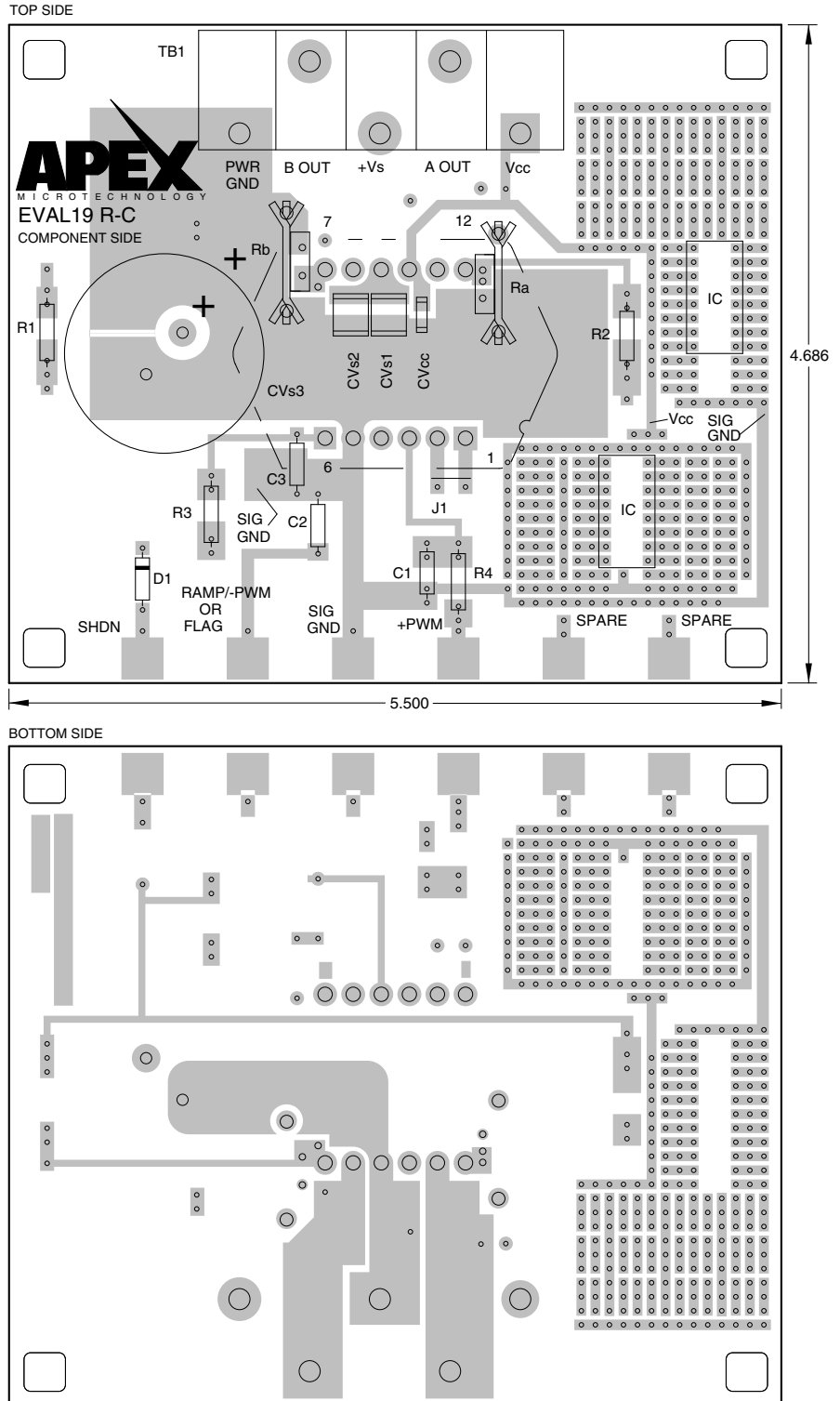

CONTACTING CIRRUS LOGIC SUPPORT

For all Apex Precision Power product questions and inquiries, call toll free 800-546-2739 in North America.

For inquiries via email, please contact apex.support@cirrus.com.

International customers can also request support by contacting their local Cirrus Logic Sales Representative.

To find the one nearest to you, go to www.cirrus.com

IMPORTANT NOTICE

Cirrus Logic, Inc. and its subsidiaries ("Cirrus") believe that the information contained in this document is accurate and reliable. However, the information is subject to change without notice and is provided "AS IS" without warranty of any kind (express or implied). Customers are advised to obtain the latest version of relevant information to verify, before placing orders, that information being relied on is current and complete. All products are sold subject to the terms and conditions of sale supplied at the time of order acknowledgment, including those pertaining to warranty, indemnification, and limitation of liability. No responsibility is assumed by Cirrus for the use of this information, including use of this information as the basis for manufacture or sale of any items, or for infringement of patents or other rights of third parties. This document is the property of Cirrus and by furnishing this information, Cirrus grants no license, express or implied under any patents, mask work rights, copyrights, trademarks, trade secrets or other intellectual property rights. Cirrus owns the copyrights associated with the information contained herein and gives consent for copies to be made of the information only for use within your organization with respect to Cirrus integrated circuits or other products of Cirrus. This consent does not extend to other copying such as copying for general distribution, advertising or promotional purposes, or for creating any work for resale.

CERTAIN APPLICATIONS USING SEMICONDUCTOR PRODUCTS MAY INVOLVE POTENTIAL RISKS OF DEATH, PERSONAL INJURY, OR SEVERE PROPERTY OR ENVIRONMENTAL DAMAGE ("CRITICAL APPLICATIONS"). CIRRUS PRODUCTS ARE NOT DESIGNED, AUTHORIZED OR WARRANTED TO BE SUITABLE FOR USE IN PRODUCTS SURGICALLY IMPLANTED INTO THE BODY, AUTOMOTIVE SAFETY OR SECURITY DEVICES, LIFE SUPPORT PRODUCTS OR OTHER CRITICAL APPLICATIONS. INCLUSION OF CIRRUS PRODUCTS IN SUCH APPLICATIONS IS UNDERSTOOD TO BE FULLY AT THE CUSTOMER'S RISK AND CIRRUS DISCLAIMS AND MAKES NO WARRANTY, EXPRESS, STATUTORY OR IMPLIED, INCLUDING THE IMPLIED WARRANTIES OF MERCHANTABILITY AND FITNESS FOR PARTICULAR PURPOSE, WITH REGARD TO ANY CIRRUS PRODUCT THAT IS USED IN SUCH A MANNER. IF THE CUSTOMER OR CUSTOMER'S CUSTOMER USES OR PERMITS THE USE OF CIRRUS PRODUCTS IN CRITICAL APPLICATIONS, CUSTOMER AGREES, BY SUCH USE, TO FULLY INDEMNIFY CIRRUS, ITS OFFICERS, DIRECTORS, EMPLOYEES, DISTRIBUTORS AND OTHER AGENTS FROM ANY AND ALL LIABILITY, INCLUDING ATTORNEYS' FEES AND COSTS, THAT MAY RESULT FROM OR ARISE IN CONNECTION WITH THESE USES.

Cirrus Logic, Cirrus, and the Cirrus Logic logo designs, Apex Precision Power, Apex and the Apex Precision Power logo designs are trademarks of Cirrus Logic, Inc. All other brand and product names in this document may be trademarks or service marks of their respective owners.
