

Low-power, 4-in / 6-out HD Audio CODEC with Headphone Amp

DIGITAL to ANALOG FEATURES

- ◆ DAC1 (Headphone)
 - 101 dB Dynamic Range (A-wtd)
 - -89 dB THD+N
- ◆ Headphone Amplifier - GND Centered
 - Integrated Negative-voltage Regulator
 - No DC-blocking Capacitor Required
 - 50 mW Power/Channel into 16 Ω
- ◆ DAC2 & DAC3 (Line Outs)
 - 110 dB Dynamic Range (A-wtd)
 - -94 dB THD+N
 - Differential Balanced or Single-ended
- ◆ Each DAC Supports 32 kHz to 192 kHz Sample Rates Independently.
- ◆ Digital Volume Control
 - +6.0 dB to -57.5 dB in 0.5 dB Steps
 - Zero Cross and/or Soft Ramp Transitions
- ◆ Independent Support of D0 and D3 Power States for Each DAC
- ◆ Fast D3 to D0 Transition
 - Audio Playback in Less Than 50 ms

ANALOG to DIGITAL FEATURES

- ◆ ADC1 & ADC2
 - 105 dB Dynamic Range (A-wtd)
 - -88 dB THD+N
 - Differential Balanced or Single-ended Inputs
 - Analog Programmable Gain Amplifier (PGA) ± 12 dB, 1.0 dB Steps, with Zero Cross Transitions and Mute
- ◆ MIC Inputs
 - Pre-amplifier with Selectable 0 dB, +10 dB, +20 dB, and +30 dB Gain Settings
 - Programmable, Low-noise MIC Bias Level
- ◆ Each ADC Supports 8 kHz to 96 kHz Sample Rates Independently
- ◆ Additional Digital Attenuation Control
 - -13.0 dB to -51.0 dB in 1.0 dB steps
 - Zero Cross and/or Soft Ramp Transitions
- ◆ Digital Interface for Two Dual Digital Mic Inputs
- ◆ Independent Support of D0 and D3 Power States for Each ADC

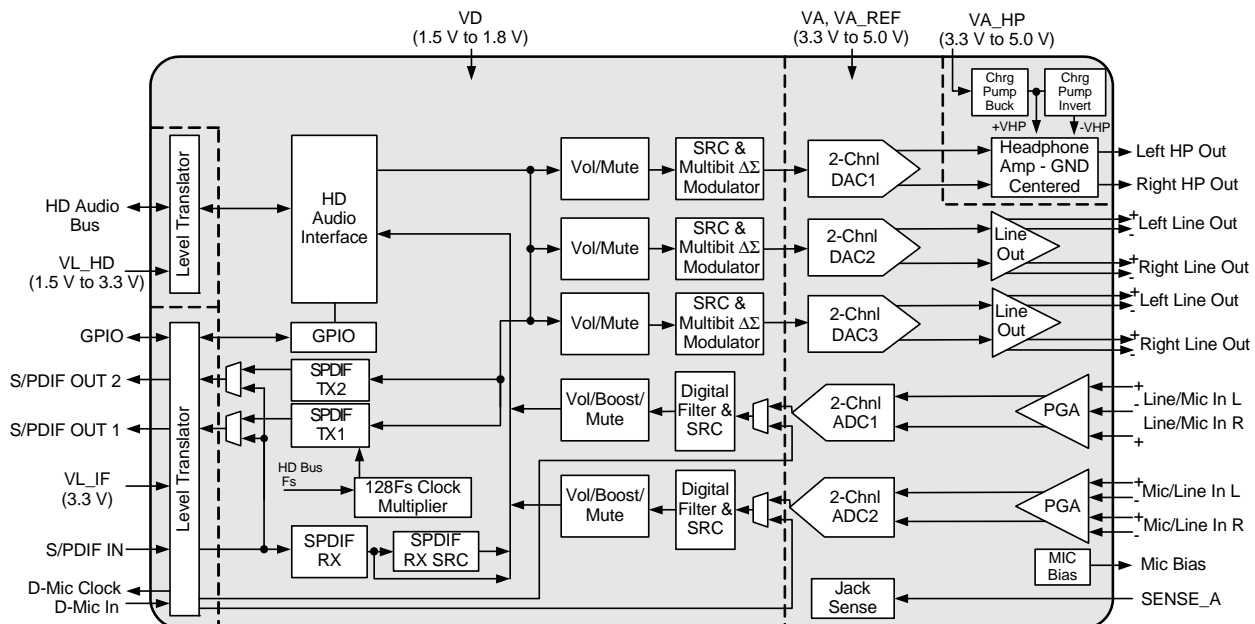

Digital Audio Interface Receiver

- ◆ Complete EIAJ CP1201, IEC-60958, S/PDIF Compatible Receiver
- ◆ 32 kHz to 192 kHz Sample Rate Range
- ◆ Automatic Detection of Compressed Audio Streams
- ◆ Integrated Sample Rate Converter
 - 128 dB Dynamic Range
 - -120 dB THD+N
 - Supports Sample Rates up to 192 kHz
 - 1:1 Input/Output Sample Rate Ratios

Digital Audio Interface Transmitters

- ◆ Two Independent EIAJ CP1201, IEC-60958, S/PDIF Compatible Transmitters
- ◆ 32 kHz to 192 kHz Sample Rate Range

System Features

- ◆ Very Low D3 Power Dissipation of <7 mW
 - Jack Detect Active in D3
 - HDA Bus BITCLK not required for D3 State
- ◆ Jack Detect Does not Require HDA Bus BITCLK
- ◆ All Configuration Settings are Preserved in D3 State
- ◆ Pop/Click Suppression in State Transitions
- ◆ Detects Wake Event and Generates Power State Change Request when HDA Bus Controller is in D3
- ◆ Variable Power Supplies
 - 1.5 V to 1.8 V Digital Core Voltage
 - 3.3 V to 5.0 V Analog Core Voltage
 - 3.3 V to 5.0 V Headphone Drivers
 - 1.5 V to 3.3 V HD Bus Interface Logic
 - 3.3 V Interface Logic levels for GPIO, S/PDIF, and Digital Mic.
- ◆ Individual Power-down Managed
 - ADCs, DACs, PGAs, Headphone Driver, S/PDIF Receiver, and Transmitters

General Description

The CS4207 is a highly integrated multi-channel low-power HD Audio CODEC featuring 192 kHz DACs, 96 kHz ADCs, 192 kHz S/PDIF Transmitters and Receiver, Microphone pre-amp and bias voltage, and a ground centered Headphone driver. Based on multi-bit, delta-sigma modulation, it allows infinite sample rate adjustment between 32 kHz and 192 kHz.

The ADC input path allows control of a number of features. The microphone input path includes a selectable programmable-gain pre-amplifier stage and a low-noise MIC bias voltage supply. A PGA is available for line and microphone inputs and provides analog gain with soft ramp and zero cross transitions. The ADC also features an additional digital volume attenuator with soft ramp transitions.

The stereo headphone amplifier is powered from a separate internally generated positive supply, with an integrated charge pump providing a negative supply. This allows a ground-centered analog output with a wide signal swing and eliminates external DC-blocking capacitors.

The integrated digital audio interface receiver and transmitters utilize a 24-bit, high-performance, monolithic CMOS stereo asynchronous sample rate converter to clock align the PCM samples to/from the S/PDIF interfaces. Auto detection of non-PCM encoded data disables the sample rate conversion to preserve bit accuracy of the data.

In addition to its many features, the CS4207 operates from a low-voltage analog and digital core, making this part ideal for portable systems that require low power consumption in a minimal amount of space.

The CS4207 is available in a 48-pin WQFN package in both Automotive (-40°C to +105°C) and Commercial (-40°C to +85°C) grades. The CS4207 Customer Demonstration board is also available for device evaluation and implementation suggestions. Please refer to [“Ordering Information” on p 8](#) for complete ordering information.

1. PIN DESCRIPTIONS

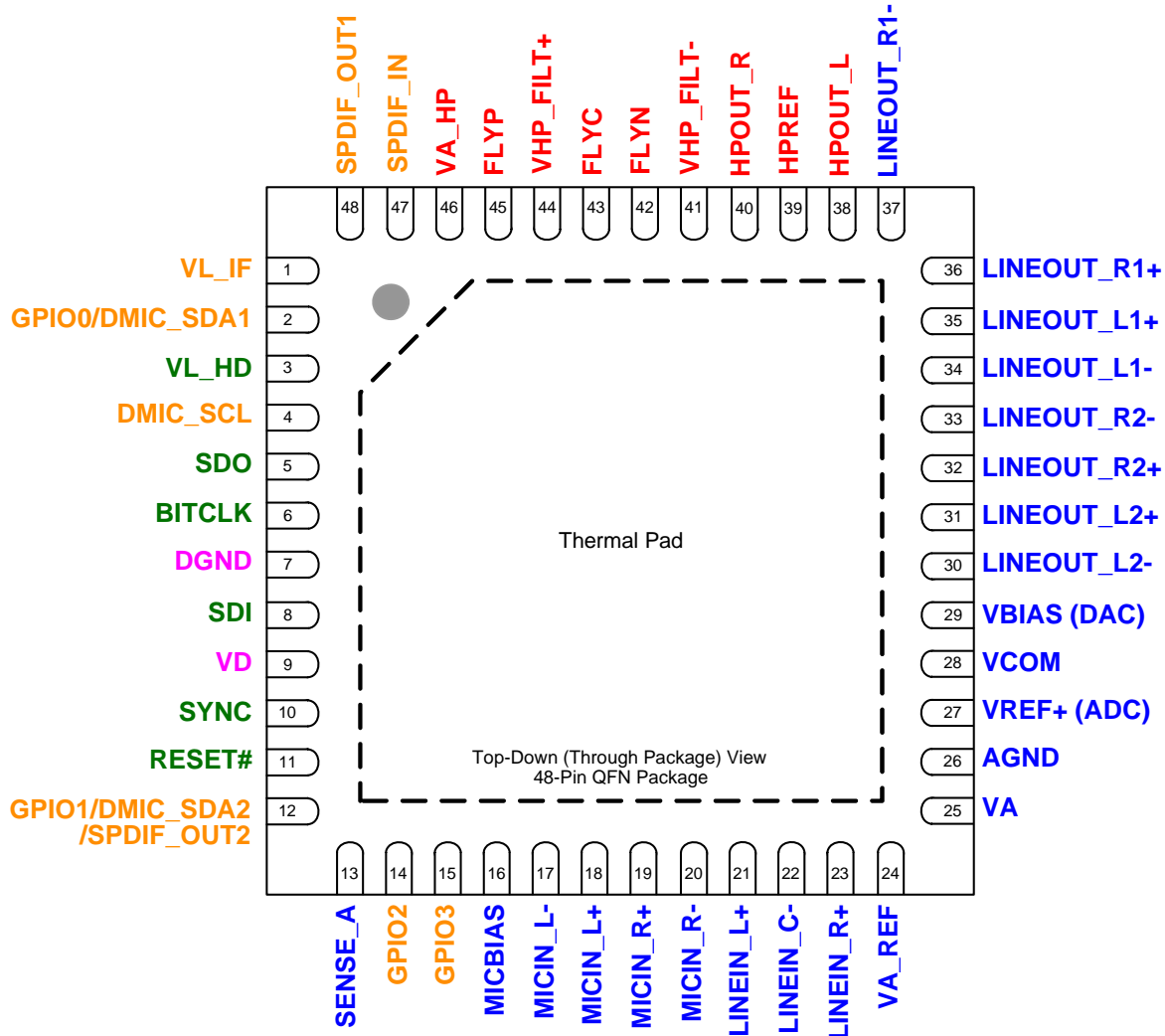

Pin Name	#	Pin Description
VL_IF	1	Digital Interface Signal Level (Input) - Determines the required signal level for the GPIO, S/PDIF and Digital Mic interfaces. Refer to the Recommended Operating Conditions for appropriate voltages.
GPIO0/ DMIC_SDA1	2	General Purpose I/O (Input/Output) - General purpose input or output line, or Digital Mic Data Input (Input) - The second data input line from a digital microphone.
VL_HD	3	Digital Interface Signal Level (Input) - Determines the required signal level for the HD Audio interface. Refer to the Recommended Operating Conditions for appropriate voltages.
DMIC_SCL	4	Digital Mic Clock (Output) - The high speed clock output to the digital microphone.
SDO	5	Serial Data Input (Input) - Serial data input stream from the HD Audio Bus.
BITCLK	6	Bit Clock (Input) - 24 MHz bit clock from the HD Audio Bus.
DGND	7	Digital Ground (Input) - Ground reference for the internal digital section.
SDI	8	Serial Data Output (Input/Output) - Serial data output stream to the HD Audio Bus.
VD	9	Digital Power (Input) - Positive power for the internal digital section.
SYNC	10	SYNC Clock (Input) - 48 kHz sync clock from the HD Audio Bus.
RESET#	11	Reset (Input) - The device enters a low power mode when this pin is driven low.

GPIO1/ DMIC_SDA2/ SPDIF_OUT2	12	General Purpose I/O (Input/Output) - General purpose input or output line, or Digital Mic Data Input (Input) - The second data input line from a digital microphone, or S/PDIF Output (Output) - Output from internal S/PDIF Transmitter.
SENSE_A	13	Jack Sense Pin (Input/Output) - Jack sense detect.
GPIO2	14	General Purpose I/O (Input/Output) - General purpose input or output lines.
GPIO3	15	General Purpose I/O (Input/Output) - General purpose input or output lines.
MICBIAS	16	Microphone Bias (Output) - Provides a low noise bias supply for an external microphone. Electrical characteristics are specified in the DC Electrical Characteristics table.
MICIN_L-	17	Microphone Input Left/Right (Input) - The full-scale level is specified in the ADC Analog Characteristics specification table.
MICIN_L+	18	
MICIN_R+	19	
MICIN_R-	20	
LINEIN_L+	21	Analog Input (Input) - The full-scale level is specified in the ADC Analog Characteristics specification table.
LINEIN_C-	22	
LINEIN_R+	23	
VA_REF	24	Analog Power (Input) - Positive power for the internal analog section. VA_REF is the return pin for the VBIAS cap.
VA	25	
AGND	26	Analog Ground (Input) - Ground reference for the internal analog section.
VREF+	27	Positive Voltage Reference (Output) - Positive reference voltage for the internal ADCs.
VCOM	28	Quiescent Voltage (Output) - Filter connection for internal quiescent voltage.
VBIAS	29	Positive Voltage Reference (Output) - Positive reference voltage for the internal DACs.
LINEOUT_L2-	30	Analog Audio Output (Output) - The full-scale output level is specified in the DAC Analog Characteristics specification table
LINEOUT_L2+	31	
LINEOUT_R2+	32	
LINEOUT_R2-	33	
LINEOUT_L1-	34	
LINEOUT_L1+	35	
LINEOUT_R1+	36	
LINEOUT_R1-	37	
HPOUT_L	38	Analog Headphone Output (Output) - The full-scale output level is specified in the DAC Analog Characteristics specification table.
HPREF	39	Pseudo Diff. Headphone Reference (Input) - Ground reference for the headphone amplifiers.
HPOUT_R	40	Analog Headphone Output (Output) - The full-scale output level is specified in the DAC Analog Characteristics specification table.
VHP_FILT-	41	Inverting Charge Pump Filter Connection (Output) - Power supply from the inverting charge pump that provides the negative rail for the headphone amplifier.
FLYN	42	Charge Pump Cap Negative Node (Output) - Negative node for the inverting charge pump's flying capacitor.
FLYC	43	Charge Pump Cap Common Node (Output) - Common positive node for the step-down and inverting charge pumps' flying capacitor.
VHP_FILT+	44	Non-Inverting Charge Pump Filter Connection (Output) - Power supply from the step-down charge pump that provides the positive rail for the headphone amplifier.
FLYP	45	Charge Pump Cap Positive Node (Output) - Positive node for the step-down charge pump's flying capacitor.
VA_HP	46	Analog Power For Headphone (Input) - Positive power for the internal analog headphone section.
SPDIF_IN	47	S/PDIF Input (Input) - Input to internal S/PDIF Receiver.
SPDIF_OUT1	48	S/PDIF Output (Output) - Output from internal S/PDIF Transmitter.
Thermal Pad	-	HP Ground (Thermal Pad) - Ground reference for the internal headphone section.

2. TYPICAL CONNECTION DIAGRAMS

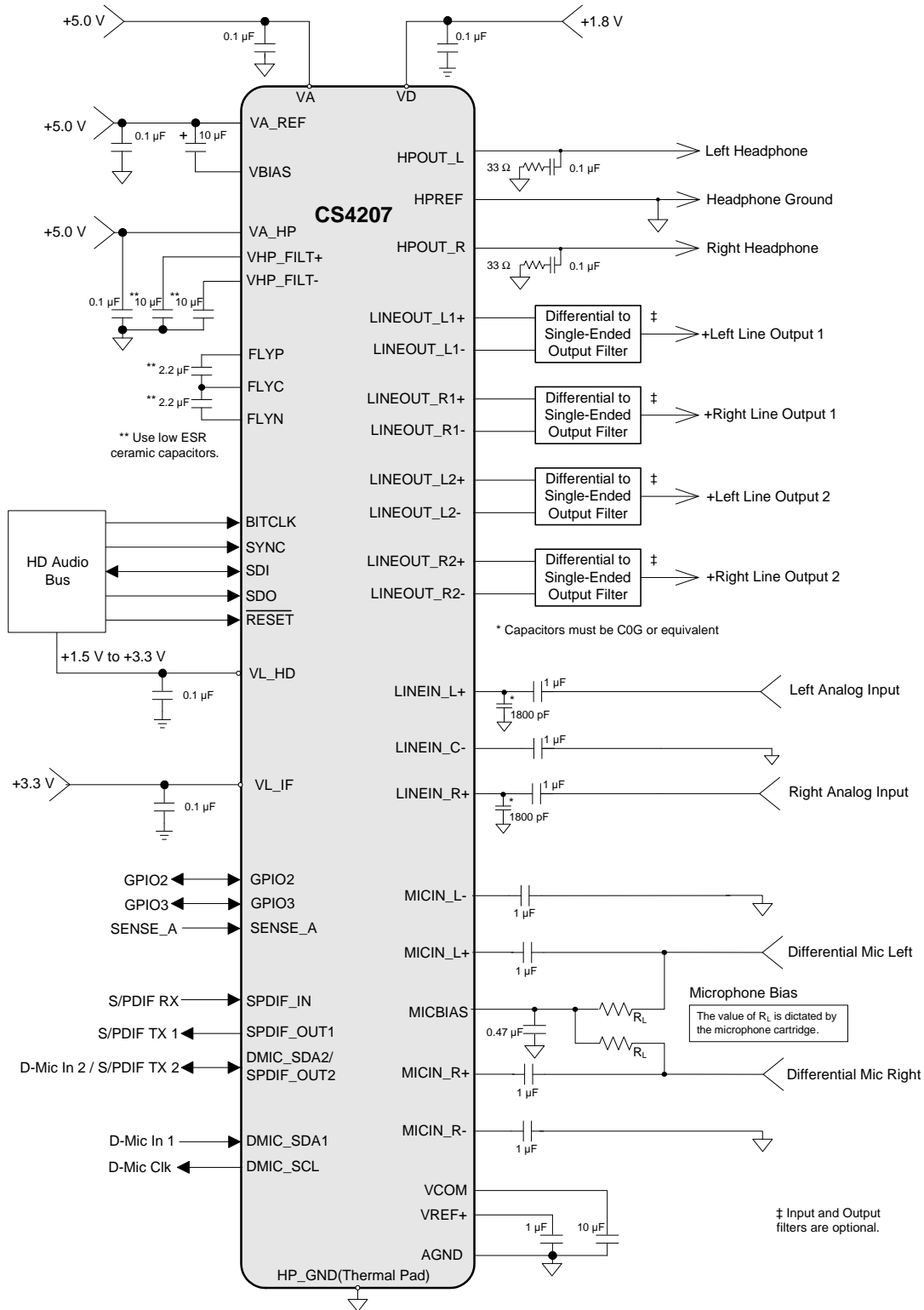
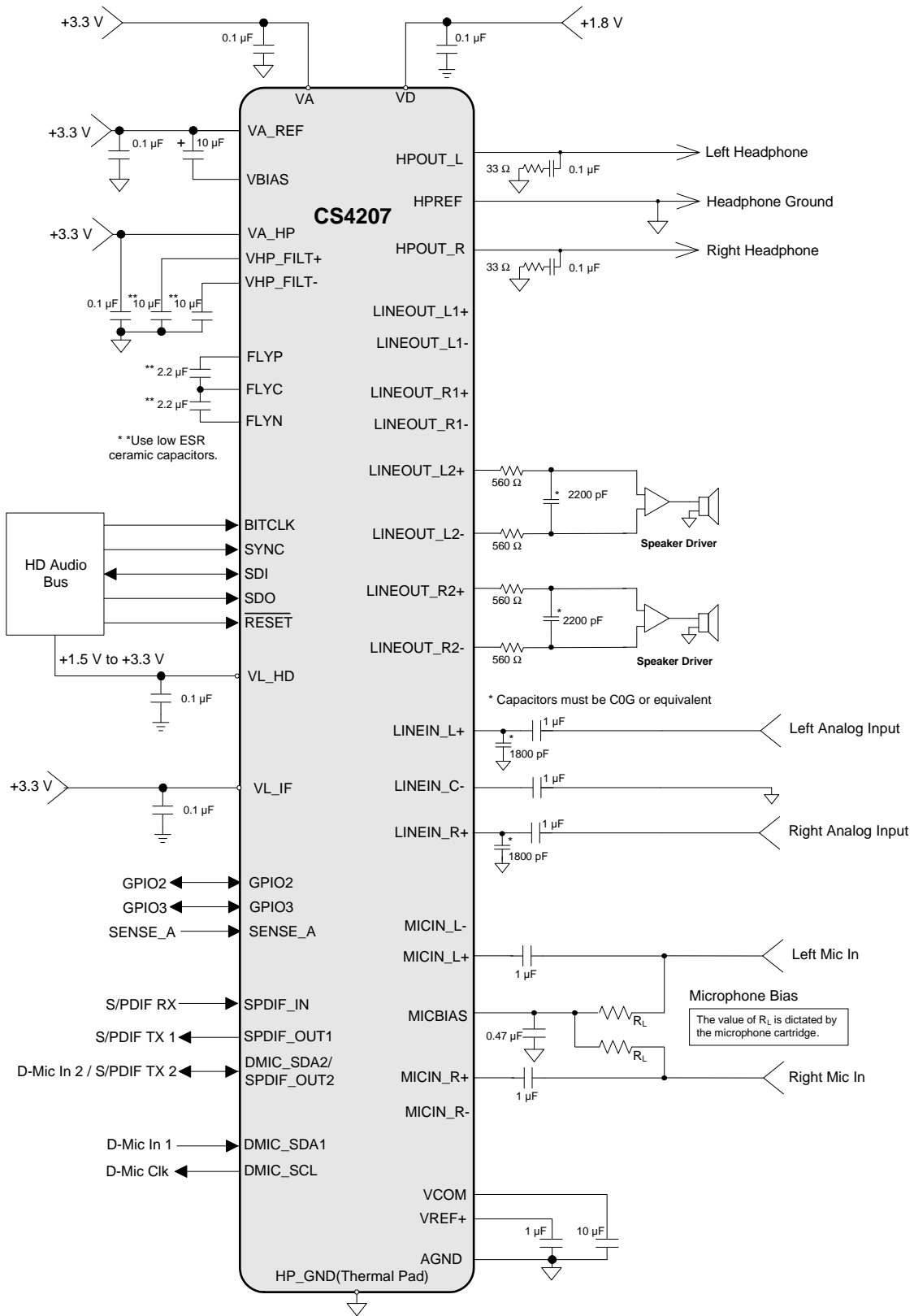
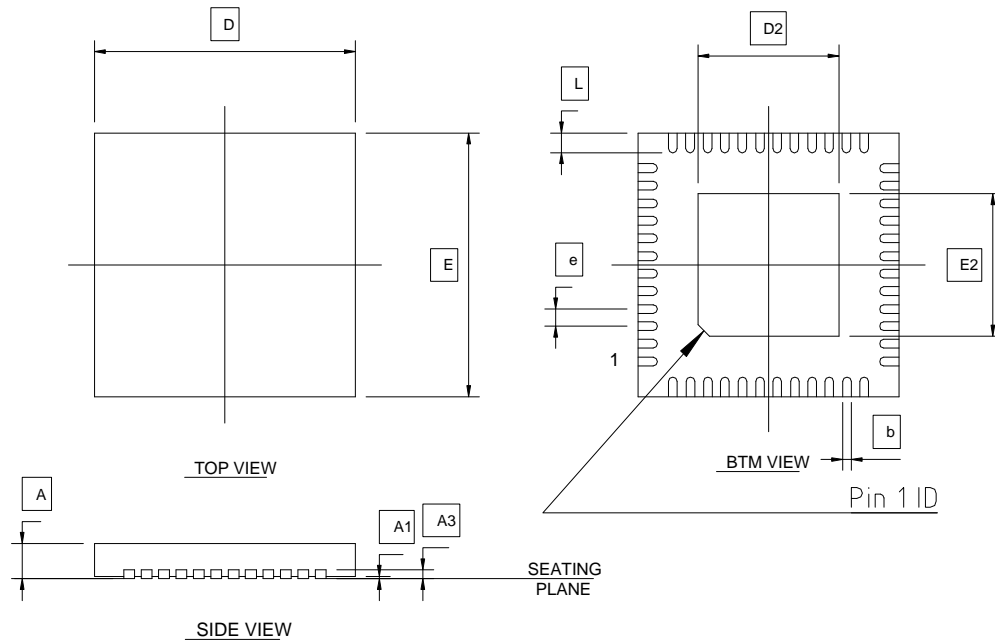

Figure 1. Typical Connection Diagram - Desktop System

Figure 2. Typical Connection Diagram - Portable System

3. PACKAGE DIMENSIONS
48LD QFN (6 X 6 mm BODY) PACKAGE DRAWING

Notes:

- 1) Controlling dimensions are in mm.
- 2) Dimensioning and tolerancing conform to ASME Y14.5m-1994
- 3) Dimension **b** applies to the metallized terminal and is measured between 0.15mm and 0.30mm from the terminal tip.
- 4) Reference JEDEC MO-229

DIM	MIN	NOM	MAX
A	0.70	0.75	0.80
A1	0.00		0.05
A3		0.20 BSC	
b	0.15	0.20	0.25
D		6.00 BSC	
D2	4.25	4.40	4.50
E		6.00 BSC	
E2	4.25	4.40	4.50
e		0.40 BSC	
L	0.35	0.45	0.55

4. ORDERING INFORMATION

Product	Description	Package	Pb-Free	Grade	Temp Range	Container	Order #
CS4207	Low Power, 4-In/6-Out HD Audio CODEC with Headphone Amp	48L-QFN	Yes	Commercial	-40°C to +85°C	Rail	CS4207-CNZ/C1
						Tape & Reel	CS4207-CNZR/C1
CS4207	Low Power, 4-In/6-Out HD Audio CODEC with Headphone Amp	48L-QFN	Yes	Automotive	-40°C to +105°C	Rail	CS4207-DNZ
						Tape & Reel	CS4207-DNZR
CDB4207	CS4207 Evaluation Board		-	-	-	-	CDB4207

5. REFERENCES

1. Intel Corporation, *High Definition Audio Specification, Revision 1.0*, April 15, 2004.
http://download.intel.com/standards/hdaudio/pdf/HDAudio_03.pdf

Contacting Cirrus Logic Support

For all product questions and inquiries, contact a Cirrus Logic Sales Representative.
 To find one nearest you, go to www.cirrus.com.

IMPORTANT NOTICE

Cirrus Logic, Inc. and its subsidiaries ("Cirrus") believe that the information contained in this document is accurate and reliable. However, the information is subject to change without notice and is provided "AS IS" without warranty of any kind (express or implied). Customers are advised to obtain the latest version of relevant information to verify, before placing orders, that information being relied on is current and complete. All products are sold subject to the terms and conditions of sale supplied at the time of order acknowledgment, including those pertaining to warranty, indemnification, and limitation of liability. No responsibility is assumed by Cirrus for the use of this information, including use of this information as the basis for manufacture or sale of any items, or for infringement of patents or other rights of third parties. This document is the property of Cirrus and by furnishing this information, Cirrus grants no license, express or implied under any patents, mask work rights, copyrights, trademarks, trade secrets or other intellectual property rights. Cirrus owns the copyrights associated with the information contained herein and gives consent for copies to be made of the information only for use within your organization with respect to Cirrus integrated circuits or other products of Cirrus. This consent does not extend to other copying such as copying for general distribution, advertising or promotional purposes, or for creating any work for resale.

CERTAIN APPLICATIONS USING SEMICONDUCTOR PRODUCTS MAY INVOLVE POTENTIAL RISKS OF DEATH, PERSONAL INJURY, OR SEVERE PROPERTY OR ENVIRONMENTAL DAMAGE ("CRITICAL APPLICATIONS"). CIRRUS PRODUCTS ARE NOT DESIGNED, AUTHORIZED OR WARRANTED FOR USE IN PRODUCTS SURGICALLY IMPLANTED INTO THE BODY, AUTOMOTIVE SAFETY OR SECURITY DEVICES, LIFE SUPPORT PRODUCTS OR OTHER CRITICAL APPLICATIONS. INCLUSION OF CIRRUS PRODUCTS IN SUCH APPLICATIONS IS UNDERSTOOD TO BE FULLY AT THE CUSTOMER'S RISK AND CIRRUS DISCLAIMS AND MAKES NO WARRANTY, EXPRESS, STATUTORY OR IMPLIED, INCLUDING THE IMPLIED WARRANTIES OF MERCHANTABILITY AND FITNESS FOR PARTICULAR PURPOSE, WITH REGARD TO ANY CIRRUS PRODUCT THAT IS USED IN SUCH A MANNER. IF THE CUSTOMER OR CUSTOMER'S CUSTOMER USES OR PERMITS THE USE OF CIRRUS PRODUCTS IN CRITICAL APPLICATIONS, CUSTOMER AGREES, BY SUCH USE, TO FULLY INDEMNIFY CIRRUS, ITS OFFICERS, DIRECTORS, EMPLOYEES, DISTRIBUTORS AND OTHER AGENTS FROM ANY AND ALL LIABILITY, INCLUDING ATTORNEYS' FEES AND COSTS, THAT MAY RESULT FROM OR ARISE IN CONNECTION WITH THESE USES.

Cirrus Logic, Cirrus, and the Cirrus Logic logo designs are trademarks of Cirrus Logic, Inc. All other brand and product names in this document may be trademarks or service marks of their respective owners.