

SOA and Load Lines

1.0 MEANING OF SOA GRAPH

SOA (Safe-Operating-Area) graphs define the acceptable limits of stresses to which power op amps can be subjected. Figure 1 depicts a typical SOA graph.

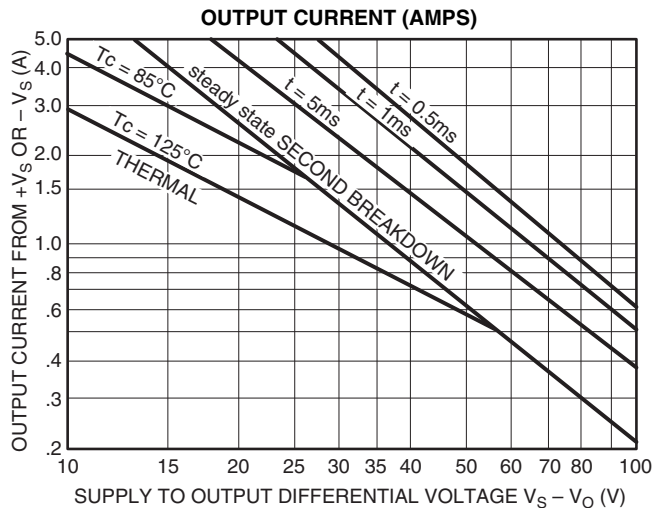

FIGURE 1. TYPICAL SOA PLOT

The voltage value on the right of the graph defines the maximum with no regard to output current or device temperature. Note that this voltage is related to the output voltage but is different; these two voltages are NOT interchangeable. The current value at the top of the graph defines maximum; again, with no regard to temperature or voltage. Inside the graph area will be one or more curves with a slope of -1 (as voltage doubles, current drops to half) labeled with a case temperature. These are constant power lines defined by DC thermal resistance and the rise from case temperature to maximum junction temperature (2.6°C/W and 200°C in this case). Lines with a steeper slope (about -1.5 in this case) are unique to bipolar output transistors. The steady state second breakdown reduces the amplifier's ability to dissipate DC power as voltage becomes more dominant in the power equation. Fortunately, the lines with time labels indicate higher power stress levels are allowed as long as duration of the power stress does not exceed the time label.

Transient SOA limits shown on data sheets are based on a 10% duty cycle pulse starting with junctions at 25°C. The repetition rate then would logically be defined by the time required for the junction to return to 25°C between pulses. Some amplifiers such as PA85 allow transient currents beyond the maximum continuous current rating. Most often though, the transient ratings are based on power or second breakdown restrictions.

2.0 ANALYTICAL METHODS

2.1 PLOTTING RESISTIVE LOAD LINES

Resistive load lines can be plotted quite easily. Keep in mind that since SOA graphs are log-log graphs, the resistive load line will have a curvature, so several points should be calculated and plotted.

Output voltage and current will always have the same polarity with a resistive load, so calculations can be performed at all times from 0 to 90° of the output cycle. Figure 2 depicts an example of resistive load line. It is interesting to note that this is a safe load which can require a 5 amp peak capability. If the output of the PA12 is unintentionally shorted to ground the voltage stress on the output will be 50 volts, which is not safe at the 5 amp current limit required to drive the load. In applications where the amplifier output would not be subject to abuse these operating conditions are acceptable. Foldback current limiting can be used to improve on the safety of this situation.

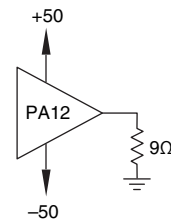

V_O	$V_S - V_O$	I_O
0	50	0
5	45	.556
10	40	1.11
15	35	1.67
20	30	2.22
25	25	2.78
30	20	3.33
35	15	3.89
40	10	4.44
45	5	5.00

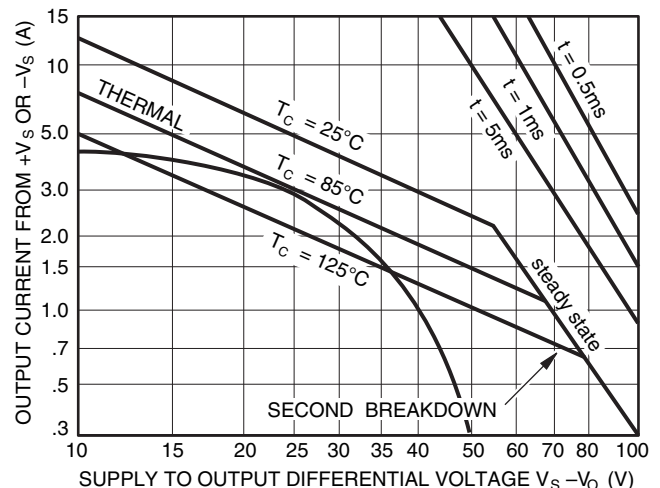

FIGURE 2. PLOTTING RESISTIVE LOAD LINE

2.2 PLOTTING REACTIVE LOAD LINES

Reactive load lines of any phase angle can be plotted with the methods shown here. A completely reactive load line almost looks like an ellipse on the SOA graph since current stresses will occur at two different levels of voltage stress.

The voltage output waveform will define the reference phase angles for all point-by-point stress calculations. The waveform shown in Figure 3 (next page), starts at -90°, since current in capacitive loads will lead in phase. The waveform ends at 270° since that corresponds to the maximum phase lag of the current in an inductive load. All calculations will be within the limits of these angles.

Calculations proceed according to the steps in Figure 4 (next page). Currents will only need to be calculated over 180° since the load line for each half of the amplifier is a mirror image. Capacitive loads will start at -90° and progress through +90°.

Inductive load calculations will start at +90° and progress to +270°. Step 2 in the procedure defines the starting angle for calculations based on the load phase angle. For example, a -45° load would start at -45° and continue to +135°. A 45° load will start at 45° and continue to 225°

VOLTAGE WAVE FORM ESTABLISHES REFERENCE PHASE ANGLE FOR ALL LOAD LINE CALCULATIONS. SHADED AREA REPRESENTS CALCULATION REGIONS

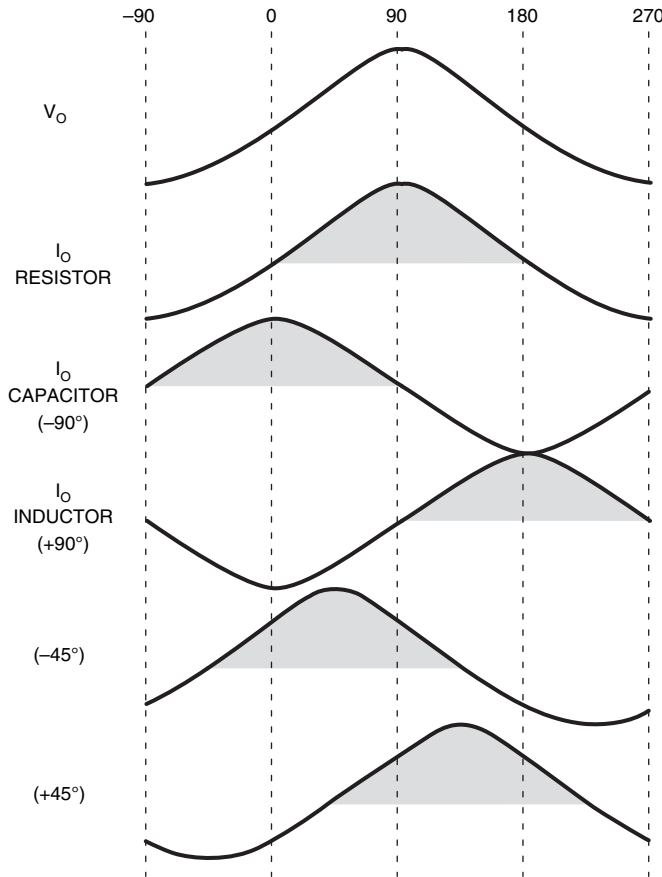

FIGURE 3. TYPICAL WAVEFORMS ASSOCIATED WITH REACTIVE LOAD LINE ANALYSIS

Example of a typical load calculation:

1. KNOWN: V_p, Z_L, θ_L
2. BEGIN POINT CALCULATIONS WITH θ_L AT $0^\circ + \theta_L$ AND PLOT FOR NEXT 180° IN WHATEVER INCREMENTS NEEDED FOR DESIRED ACCURACY (15° OR 30° INCREMENTS RECOMMENDED.)
3. $I_{pk} = \frac{V_p}{Z_L}$ CALCULATE ONLY ONCE
4. CALCULATE EACH INCREMENT:
 $I = I_{pk} (\sin(\theta_v - \theta_L))$
5. CALCULATE EACH INCREMENT:
 $V_d = V_s - V_p (\sin \theta_v)$

FIGURE 4. REACTIVE LOAD CALCULATIONS

In the resistive load example the load line of a 9 ohm resistive load was plotted and was quite safe. For this example let's use the same impedance but with a 60° phase angle.

Figure 5 shows a PA12 driving an inductive load of 9 ohm at 60°. From step 2 of our procedure we know we begin calculating current at 60° and continue to 60+180 or 240°. For

this example we will use 15° increments. Actually, it is only necessary to perform the step-by-step calculations for current up to the point where peak current occurs, in this case 150°. The increments back down to 240° will be a mirror image of what was just calculated. However, don't get this lazy with the voltage calculations we have yet to do.

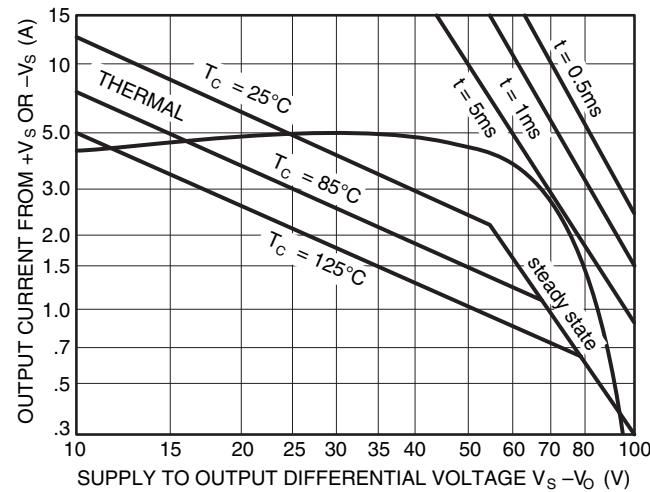
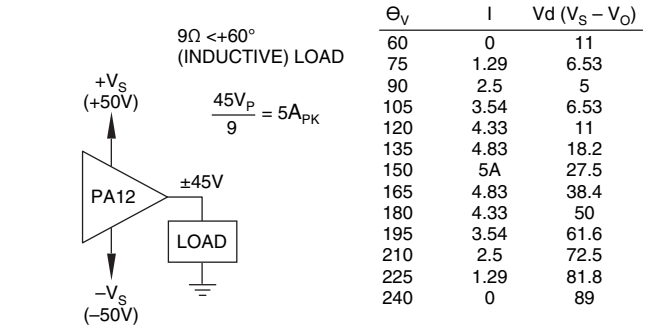

(NOTE THAT $Pd_{max} = \frac{V_s^2}{2Z_L} \left| \frac{4}{\pi} - \cos \theta_L \right| = 107 \text{ w}$)

FIGURE 5. TYPICAL LOAD LINE CALCULATIONS

Even though the point of maximum voltage stress occurring at full negative output swings is not evident in the voltage stress calculations, it is inconsequential since we have established that no current flows through the output device at that time. As long as the amplifier itself is within its voltage ratings, all will be well.

After all points are calculated, they may be plotted on the SOA graph. In this particular case note there are significant excursions beyond the steady state 25°C SOA limit. Is this acceptable? Consider the following factors to help make the decision: 1. The area beyond the continuous SOA is quite sizeable. 2. A calculation of maximum average power dissipation using the formula shown in Fig 5 (refer to General Operating Considerations for background on this calculation) shows the amplifier dissipating 107 watts.

The 107 watt dissipation will certainly cause the amplifier to operate at significantly elevated temperatures, even with a generous heatsink. Realistically the SOA limits are being reduced by the heating. We can even define exactly how badly. Assume a 25°C ambient (that's pretty optimistic). Using an HS05 heatsink rated 0.85°C/watt results in an amplifier case temperature 91°C. It is evident that the PA12 is not well suited

for this application. The alternatives include either paralleling PA12s or upgrading to a PA05.

2.3 SPECIAL CASES OF LOAD LINE PLOTTING AND OTHER GENERALIZATIONS

For parallel connected amplifiers, assume each amplifier drives a load rated at half the current of the total load. In essence, double the load impedance. Do just the opposite for a bridge circuit.

Some simple relationships to keep in mind: for totally reactive loads maximum current occurs at a voltage stress corresponding to V_s and maximum dissipation occurs at a voltage stress of $V_s + (0.707V_s)$, where current is also $0.707 \cdot I_{peak}$. In a resistive load, stresses are much less with maximum current occurring at maximum output voltage swing. This generally corresponds to the maximum swing specification given in every amplifier data sheet.

Also keep in mind that there are many load lines which will fit well within an amplifier SOA and be quite safe to drive. Yet these same loads can demand current capability that requires current limits be set so high the amplifier output will not be able to tolerate inadvertent shorts on its output. This is usually acceptable in applications with committed loads; however, applications where the amplifier output terminals are accessible to poorly defined loads or fault conditions demand fault tolerance on the part of the amplifier. A good example is a set of screw terminals like those found as the output connectors of an audio amplifier.

The methods shown here calculate load lines for reactive loads at only one frequency. For inductive loads worst case stresses will occur at the lowest frequency of interest with the opposite true for capacitive loads.

MOSFET amplifiers have an important difference from bipolar amplifiers regarding SOA limits: MOSFETs are only limited by power dissipation, or the product of $V \cdot I$ stress. Bipolar amplifiers are power limited up to certain voltages indicated on the SOA graphs, where second breakdown imposes even lower limits on safe current than power dissipation would allow.

2.4 PLOTTING AMPLIFIER CURRENT LIMITS

Additional information which can be plotted on the SOA graph to help assess amplifier safety is the current limit of the amplifier. Simple fixed current limiting is simply plotted along the current corresponding to that limit. Any load line excursions beyond that level can be disregarded. They are simply not possible.

Figure 6A depicts the SOA graph from Figure 5 with a fixed current limit drawn in. The fixed limit is set to 1.5 amps to provide short circuit safety at up to 85°C case temperature. It is obvious the load line is totally outside this current limit. The maximum available output will be set by the 1.5 amp current limit and impedance of the load. Or in the case of a resistive load, the lowest load impedance is a function of maximum output voltage and current limit.

Foldover current limiting can also be plotted on an SOA graph. This is important with inductive loads since foldover limiting in conjunction with inductive loads can cause more problems than it solves unless applied carefully. When foldover current limiting occurs with an inductive load, a violent flyback spike occurs that transitions all the way up to one of the supply rails. External ultra-fast recovery flyback diodes are a must when combining foldover limiting and inductive loads. It is also possible for relaxation oscillation to occur. This can be prevented by insuring that the normal inductive load line is well within

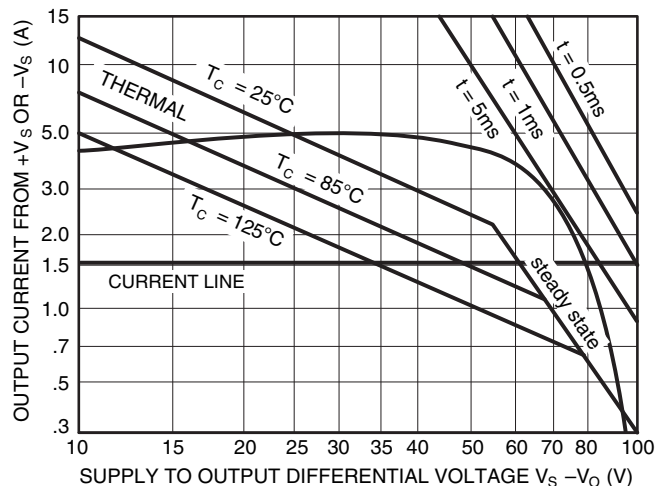

A FIXED 15A CURRENT LIMIT

$$\text{Max } V_O(\text{PEAK}) \text{ REACTIVE} = I_{LIM} \times Z_L$$

$$\text{LOWEST POSSIBLE } R_L = \frac{V_O(\text{PK})}{I_{LIM}} = \frac{45}{1.5} = 30\Omega$$

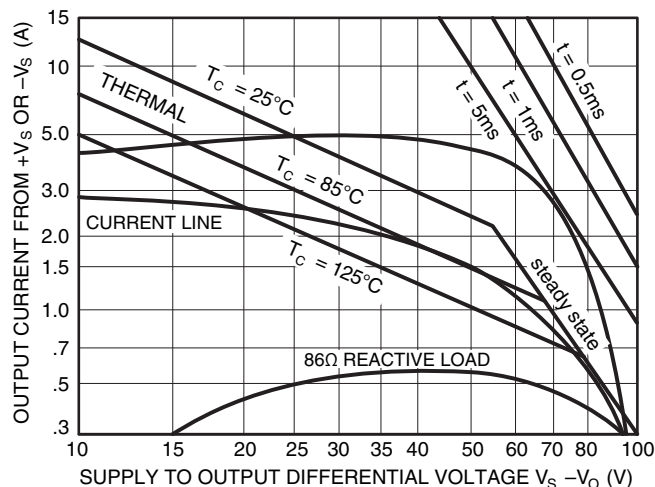

B FOLDOVER CURRENT LIMIT

$$R_{CL} = 0.433\Omega \quad \text{PIN 7 OF PA12 GROUNDED}$$

$$I_O = \frac{.65 + V_O \left(\frac{.28}{20} \right)}{R_{CL}}$$

$$\text{LOWEST POSSIBLE } R_L = \frac{45}{2.8} = 16\Omega$$

REACTIVE LOAD

$$0.707 I_{PK} @ V_s + 0.707 (V_s) = 50 + 35 = 85V$$

$$I_{LIM} @ 85V = 370 \text{ mA}$$

$$\frac{0.707 V_O}{0.37A} = \frac{0.707 \times 45}{0.37} = 86\Omega$$

FIGURE 6. PLOTTING CURRENT LIMITS

all limiting values.

Figure 6B portrays foldover limiting according to formulas contained in Application Note 9 or the PA12 data sheet. The load of Figure 5 obviously cannot be driven. Note that with foldover limiting a peak current of 2.8 amps is available yet short circuit current is limited to 1.5 amps making it possible to safely drive a 16 ohm resistive load. To determine the minimum acceptable value for a reactive load, consider that 70.7% of peak current

occurs at a voltage stress of $V_s + (0.707V_s)$. A reactive load line within that operating point will likely be within all operating points and representative of minimum acceptable load.

Figure 6B depicts the worst case acceptable reactive load. It really doesn't fill up much of the permissible operating region, but such are the trade-offs involved in driving difficult loads.

3.0 BENCH TESTING SOA

An oscilloscope can be used to do real world plotting of load lines on actual working circuits. The SOA limits can be drawn in on the scope screen if necessary. First, the SOA limits should be redrawn on linear-linear graph paper. This results in an SOA graph as shown in Figure 7A. The graph shown is for a PA12 bipolar amplifier, and second breakdown causes the break in the shape at 55 volts. MOSFET amplifiers will have a continuous curve representative of power dissipation. This can then be transferred to a transparency sized to properly fit on a scope screen.

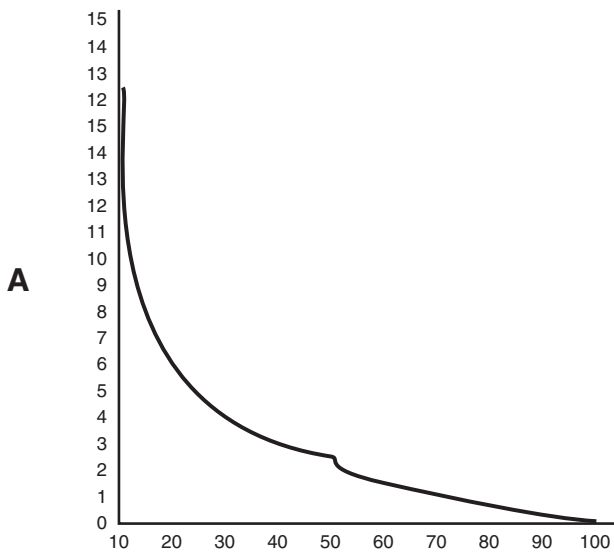

PAI2 PLOT OF 25 C STEADY STATE SOA ON LINEAR GRAPH

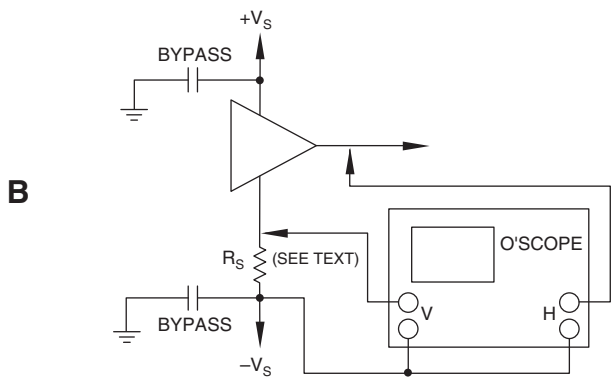

FIGURE 7. OSCILLOSCOPE TESTING OF SOA

The easiest method of connecting a scope to plot actual output device stresses will be to refer the scope ground to the negative supply of the circuit as shown in Figure 7B. This connection results in the proper phases for easy viewing on the oscilloscope. Since the oscilloscope ground is connected to the negative supply line, be certain there is ground isola-

tion either in the amplifier power supply or the oscilloscope is connected to an isolation transformer.

R_s is a current sensing resistor. When possible, use of a 1 ohm resistor provides a direct scale factor on the vertical input of volts = amps. If other values must be used consider scaling accordingly. The current sense resistor must be right at the amplifier power pin. This is one of those rare cases where it is temporarily necessary to violate the rules of proper power supply bypassing. Any capacitance present at the node, where the resistor meets the amplifier will interfere with high frequency measurements. If an oscilloscope current probe is available it is certainly preferable to the current sensing resistor since it provides accuracy and speed without having to disrupt the circuit.

4.0 SOA MEASUREMENT CIRCUITS

Another means of analyzing SOA stresses in operating circuits uses an analog multiplier to calculate real time instantaneous power dissipation. This method is especially applicable where second breakdown is not encountered. For example, working with MOSFET amplifiers under any condition or most bipolar amplifiers at total rail-to-rail supply voltages of less than 30 volts.

The circuit shown in Figure 8 senses output device current and voltage stress as is done with an oscilloscope. Differential amplifiers with wide common-mode ranges are used for sensing these values and levels, translating them to be applied to an analog multiplier. The output of the multiplier will be the product of the voltage and current stress on the output device. The R_s current sense resistor must be in the supply line so current is measured in only the output device corresponding to the voltage stress measurement.

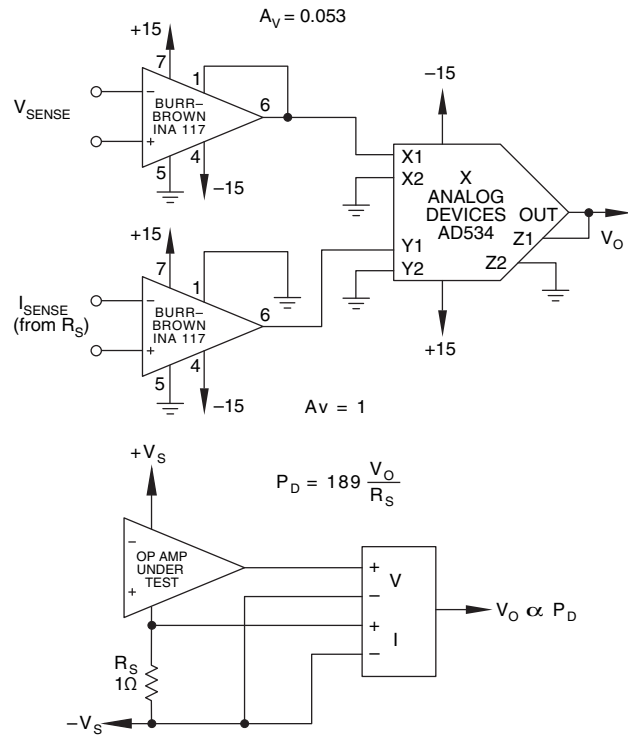

FIGURE 8. INSTANTANEOUS POWER DISSIPATION TESTER

This circuit provides a signal indicating instantaneous power dissipation. When working with a MOSFET amplifier such as the PA04, the designer should be concerned that this output be

$$Z_L = |Z_L|$$

$$P_{D(O\text{UT})\text{MAX}} = \frac{2Vs^2}{\pi^2 Z_L \text{Cos}\Theta}, \Theta < 40$$

$$P_{D(O\text{UT})\text{MAX}} = \frac{Vs^2}{2Z_L} \left[\frac{4}{\pi} - \text{Cos}\Theta \right] \Theta > 40$$

$$P_{\text{TOTAL}} = P_{D(O\text{UT})\text{MAX}} + P_{D(IQ)}$$

within the 200 watt dissipation of the PA04, or less if elevated temperatures are considered.

5.0 OTHER FACTORS FOR DETERMINING SOA FIT

Since different SOA limits are shown for different temperatures, it is helpful to be able to predict the amplifier temperature. One factor that only the designer can define is ambient temperature. In particular, maximum ambient temperature.

Amplifier power dissipation will also be a factor in determining case temperature. Equations for predicting power dissipation maximums are discussed in the Apex Precision Power Handbook, "General Operating Considerations" section 7.0, and the equations are shown here for convenience:

Once worst case dissipation is known, use the heat sink thermal resistance and ambient temperature to calculate amplifier case temperature since SOA temperature limits are based on case temperature.

Effects of current limiting with reactive loads can also be evaluated when plotting load lines. Current limit lines can be drawn on the SOA representing current limit values. If reactive loads exceed these limits, distortion will occur. Often an inductive load causes what appears at first to be crossover distortion when viewing an amplifier output. In fact, what is actually occurring is that the current peaks when voltage transitions through zero and a light excursion into current limit looks much like crossover distortion.

Foldover current limits can be plotted on SOA graphs point by point as is done with load lines. Again, reactive loads must fit well within current limits. This is especially important when relaxation oscillation can occur if current limits are exceeded. In such cases the foldover effect must be reduced or even eliminated.

CONTACTING CIRRUS LOGIC SUPPORT

For all Apex Precision Power product questions and inquiries, call toll free 800-546-2739 in North America.

For inquiries via email, please contact apex.support@cirrus.com.

International customers can also request support by contacting their local Cirrus Logic Sales Representative.

To find the one nearest to you, go to www.cirrus.com

IMPORTANT NOTICE

Cirrus Logic, Inc. and its subsidiaries ("Cirrus") believe that the information contained in this document is accurate and reliable. However, the information is subject to change without notice and is provided "AS IS" without warranty of any kind (express or implied). Customers are advised to obtain the latest version of relevant information to verify, before placing orders, that information being relied on is current and complete. All products are sold subject to the terms and conditions of sale supplied at the time of order acknowledgment, including those pertaining to warranty, indemnification, and limitation of liability. No responsibility is assumed by Cirrus for the use of this information, including use of this information as the basis for manufacture or sale of any items, or for infringement of patents or other rights of third parties. This document is the property of Cirrus and by furnishing this information, Cirrus grants no license, express or implied under any patents, mask work rights, copyrights, trademarks, trade secrets or other intellectual property rights. Cirrus owns the copyrights associated with the information contained herein and gives consent for copies to be made of the information only for use within your organization with respect to Cirrus integrated circuits or other products of Cirrus. This consent does not extend to other copying such as copying for general distribution, advertising or promotional purposes, or for creating any work for resale.

CERTAIN APPLICATIONS USING SEMICONDUCTOR PRODUCTS MAY INVOLVE POTENTIAL RISKS OF DEATH, PERSONAL INJURY, OR SEVERE PROPERTY OR ENVIRONMENTAL DAMAGE ("CRITICAL APPLICATIONS"). CIRRUS PRODUCTS ARE NOT DESIGNED, AUTHORIZED OR WARRANTED TO BE SUITABLE FOR USE IN PRODUCTS SURGICALLY IMPLANTED INTO THE BODY, AUTOMOTIVE SAFETY OR SECURITY DEVICES, LIFE SUPPORT PRODUCTS OR OTHER CRITICAL APPLICATIONS. INCLUSION OF CIRRUS PRODUCTS IN SUCH APPLICATIONS IS UNDERSTOOD TO BE FULLY AT THE CUSTOMER'S RISK AND CIRRUS DISCLAIMS AND MAKES NO WARRANTY, EXPRESS, STATUTORY OR IMPLIED, INCLUDING THE IMPLIED WARRANTIES OF MERCHANTABILITY AND FITNESS FOR PARTICULAR PURPOSE, WITH REGARD TO ANY CIRRUS PRODUCT THAT IS USED IN SUCH A MANNER. IF THE CUSTOMER OR CUSTOMER'S CUSTOMER USES OR PERMITS THE USE OF CIRRUS PRODUCTS IN CRITICAL APPLICATIONS, CUSTOMER AGREES, BY SUCH USE, TO FULLY INDEMNIFY CIRRUS, ITS OFFICERS, DIRECTORS, EMPLOYEES, DISTRIBUTORS AND OTHER AGENTS FROM ANY AND ALL LIABILITY, INCLUDING ATTORNEYS' FEES AND COSTS, THAT MAY RESULT FROM OR ARISE IN CONNECTION WITH THESE USES.

Cirrus Logic, Cirrus, and the Cirrus Logic logo designs, Apex Precision Power, Apex and the Apex Precision Power logo designs are trademarks of Cirrus Logic, Inc. All other brand and product names in this document may be trademarks or service marks of their respective owners.
