

APEX
MICROTECHNOLOGY

POWER FOR THE ANALOG WORLD

Basic PWM Transfer Function

$$V_o = \frac{V_{mid}-V_{in}}{V_{pk}} * V_s - I_o * R_{on}$$

V_o = output voltage
 V_{mid} = ramp midpoint
 V_{in} = input voltage
 V_{pk} = 1/2 ramp V_{p-p}
 V_s = supply voltage
 I_o = output current
 R_{on} = total on resistance

$$\text{Gain} = \frac{2 * V_s}{V_{ramp\ p-p}} * \frac{V_{mid}-V_{in}}{V_{pk}} \Rightarrow +/-1$$

Speaking of a full bridge FET amplifier:

The first term of the output equation concerns duty cycle and is arranged to numerically yield a range from -1 to +1.

Multiplying by the second term yields +Vs to -Vs (even though there is no -Vs). For IGBT amplifiers, forward drop would be subtracted from Vs prior to multiplying.

The last two terms represent internal loss in the switches.

Manipulating the equations a little tells us gain is the ratio of twice the supply to the ramp peak-to-peak amplitude. This is important for stability evaluation.



Basic PWM Transfer Function

$$V_o = \frac{V_{mid} - V_{in}}{V_{pk}} * V_s - I_o * R_{on}$$

V_o = output voltage

V_{mid} = ramp midpoint

V_{in} = input voltage

V_{pk} = 1/2 ramp V_{p-p}

V_s = supply voltage

I_o = output current

R_{on} = total on resistance

- Poor load regulation
- Temperature sensitive
- No supply rejection
- Close the loop!

Op amps are very seldom run open loop because the gain is unmanageable. With a much lower gain, there is a temptation to run PWM amplifiers open loop. Here are the major limitations of open loop PWM operation.

We tend to not worry about op amp output impedance because it is reduced to an insignificant level by the loop gain of the amplifier. On resistance of PWM amplifiers ranges from about 0.16Ω (30A model) to 0.5Ω (10A model) resulting in load regulation errors up to several volts.

To make matters worse, these on resistances increase by about 2 times between JUNCTION temperatures of 25°C and 150°C !

Those of us accustomed to working with power op amps take power supply rejection for granted; at least at low frequencies, so supply voltage changing a few percent is of no concern. The open loop PWM circuit offers NO supply rejection.

Accuracy and open loop operation of a PWM amplifier do NOT go together.

Closing this loop can be done locally in the voltage mode and with most models in the current mode. The alternative is closing the loop with system components. This often involves mechanical components, velocity or position sensors and a computer.

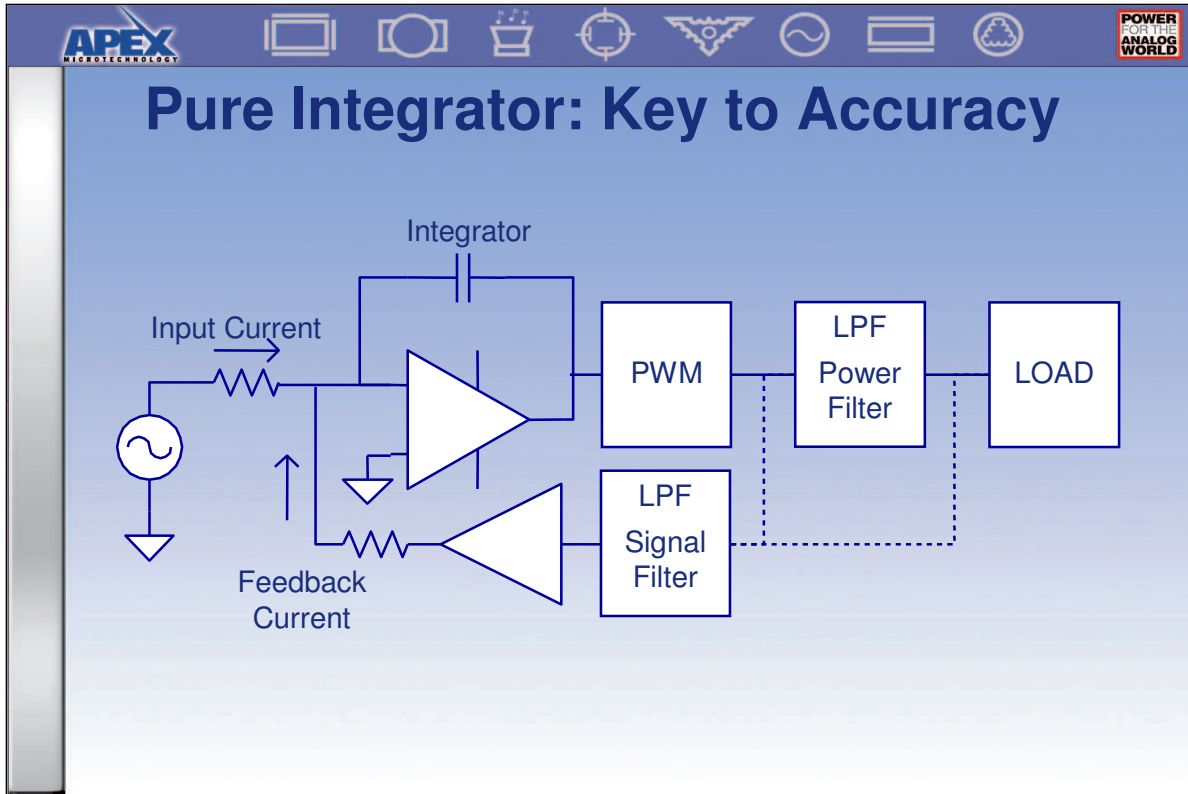

Here is very general look at closing a PWM amplifier locally. The PWM output is filtered and delivered to the load as a power analog signal (occasionally a load may do its own filtering). A feedback circuit usually contains a low pass filter and often an amplifier. It has multiple topology options to monitor voltage, current or process variables such as position or temperature. The feedback circuit provides a voltage representation of the job actually being done.

The integrator now drives the PWM input where ever required to force input and feedback currents to be equal and opposite. Considering the job of the feedback circuit, the integrator forces the job being done to follow the input voltage command.

When the loop is closed, output voltage changes due to variations in load, supply and temperature are greatly reduced.

Ref. AN39

A SLOW COMPARATOR?

The diagram shows an operational amplifier (op-amp) configured as an integrator. The non-inverting input (+) is connected to ground. The inverting input (-) is connected to an AC voltage source through a resistor. A capacitor is connected between the output and the inverting input, forming a feedback loop. This configuration is used to examine the basic operation of the op-amp integrator.

No, this slide is not a mistake, its just a way to examine the basic operation of the op amp integrator.

Any one for a slow comparator? That's what we find here, where the feedback capacitor slows down the transition time. During the transition, the op amp is likely operating in a linear closed loop fashion. The input signal sets a current in R_{IN} because of the virtual ground property of the inverting input. With no current in or out of the op amp input pins, the input current path is through the feedback capacitor to the op amp output. Voltage is developed across a given capacitor, governed by the time and magnitude of the input. Linear operation ceases when the output of the op amp cannot meet the current requirement. This happens when the op amp slew rate, current capability or most often, voltage swing capability is exceeded. This is fine, the comparator has done its job of switching, with a controlled transition rate.

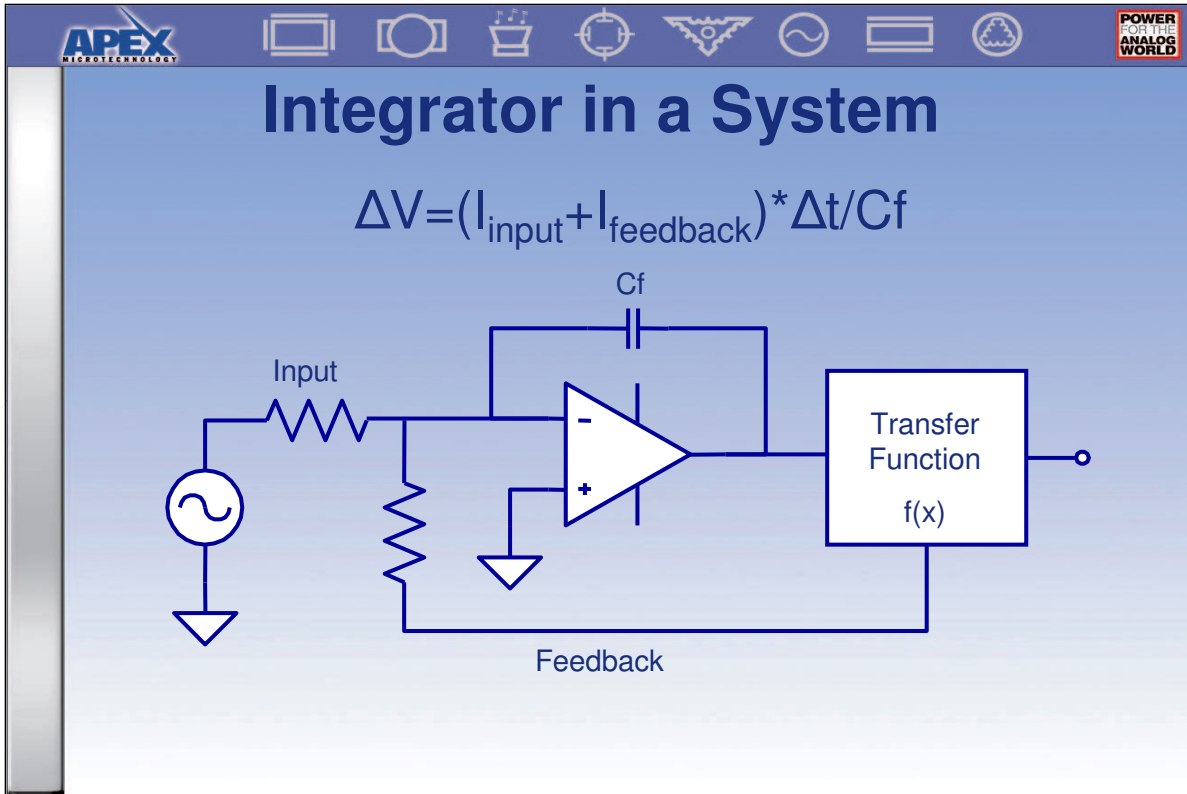

With a little modification, we can transform this switching circuit into a very useful linear tool. What is required is a form of feedback to maintain operation in the transition area, or the linear area. This figure shows a generalized form of this where $f(x)$ is non-inverting. This function is often non-linear, but seldom contains step junctions.

Confining our analysis to linear operation, there is no current in the op amp input pins. Looking at the summing junction with three connections, current in any given path must equal the sum of the other two paths. Therefore, capacitor current will be the algebraic sum of the input and feedback currents.

If I_{IN} and I_{FDBK} are equal and opposite, the output does not move.

Notice that our rule on movement of the output does NOT predict absolute level, only direction and rate of movement. This can be a magical elixir for many $f(x)$ functions.

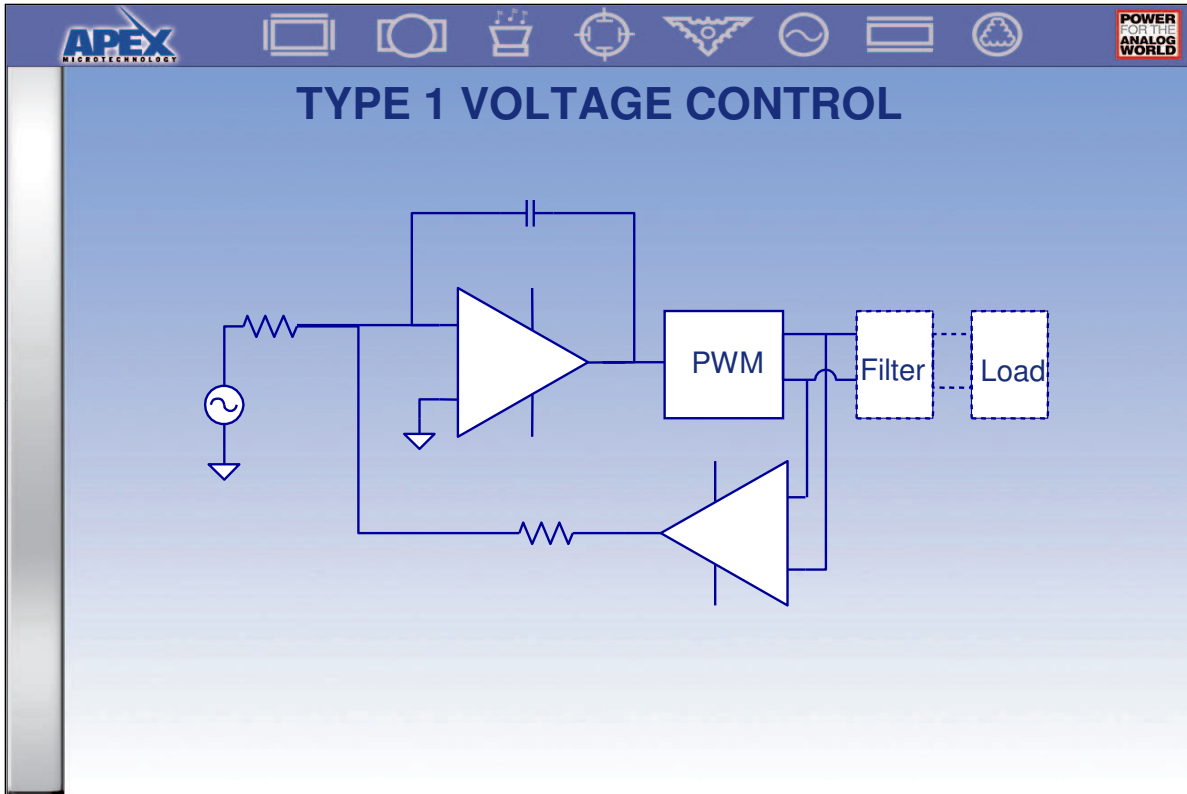

This simple voltage control circuit illustrates that in addition to improving accuracy over open loop operation, the integrator simplifies circuit design. Assume the input and feedback resistors are equal and that the gain of the differential feedback amplifier is $1/10$. This tells us right away that the circuit gain is 10.

The function of this circuit can be determined using simple op amp rules- -without ever having to calculate a duty cycle. The idea is to let the PWM handle the power and let the op amp(s) handle signal control- -the brawn, and the brains.

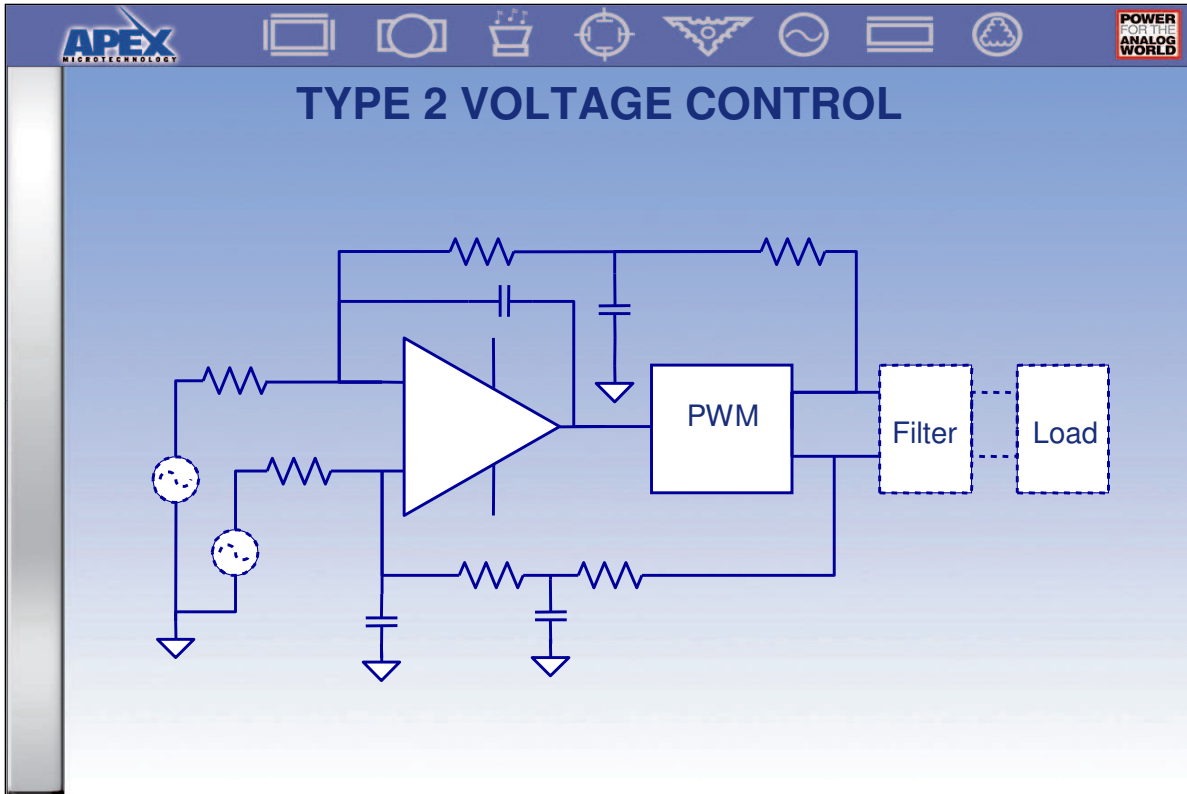

By substituting a second PWM output for the voltage reference of the previous circuit, and adding a low pass power filter, we have simple control of a high power drive with a minimum component count.

Note that we have split R_f into two resistors to facilitate the addition of a low pass small signal filter so the op amp does not have to contend with large square waves at the switching frequency.

Just as in the previous circuit, the components on the plus and minus sides need to be matched.

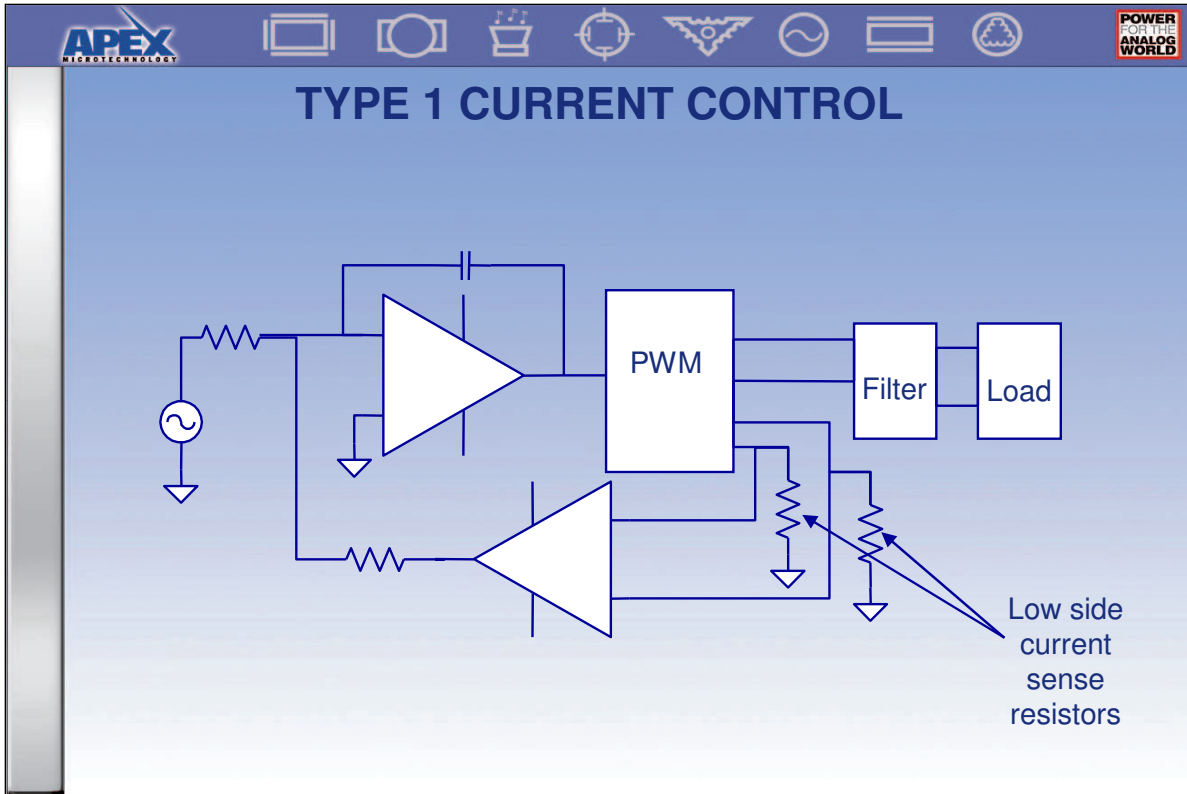

Remember the four switches configured as an H-bridge? Underneath the two lower switches, we insert low value sense resistors to monitor current. As the load current changes polarity, the current path switches resistors. With a differential amplifier looking at both resistors, it will output a bipolar voltage corresponding to the bipolar current in the load.

Again, we find simple op amp rules controlling the high power PWM amplifier.

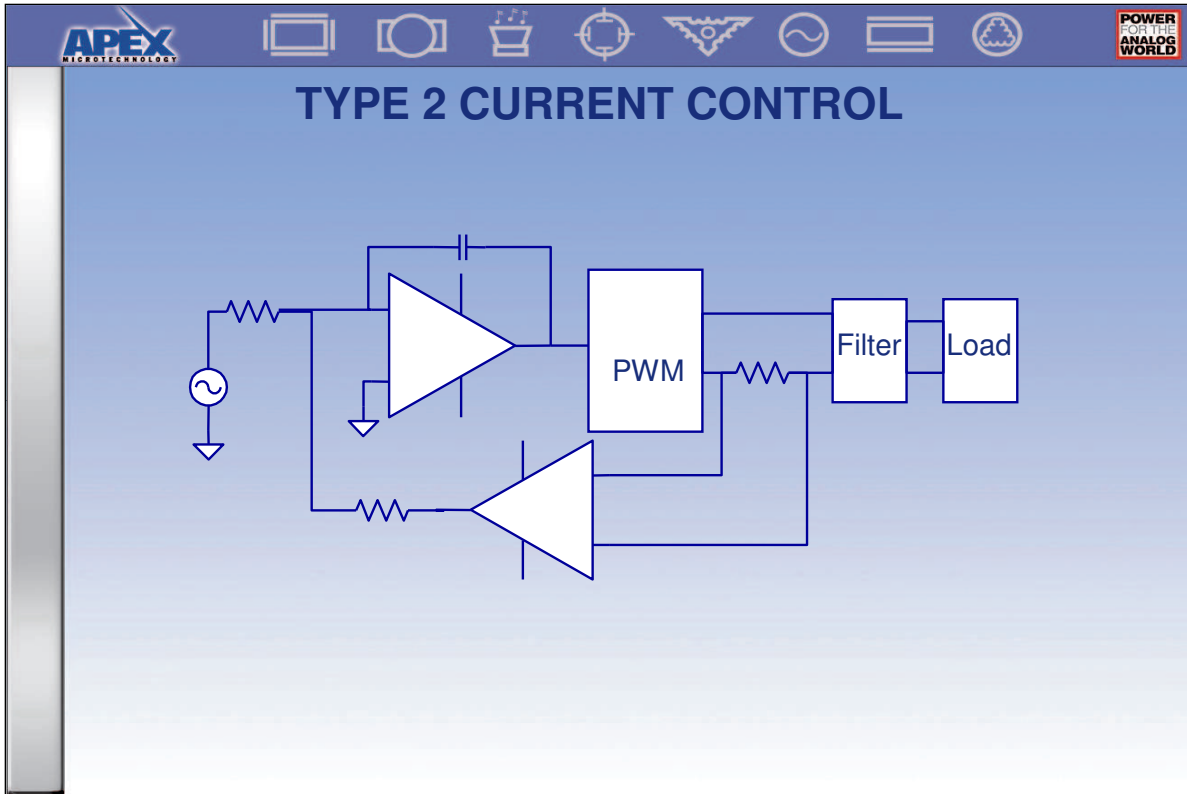

In our business, almost everyone likes smaller packages. However, pin count comes down with size and this leaves a couple models with the two current sense points tied inside the package to save a pin. Magnitude information is present and can be used for current limiting, but direction information is lost.

In this case a sense resistor in series with the load, plus a differential amplifier can get a current control circuit up and running.

Beware the common mode voltage fed to this difference amplifier will be up to the main supply voltage of the PWM amplifier.



PWM MOTION CONTROL

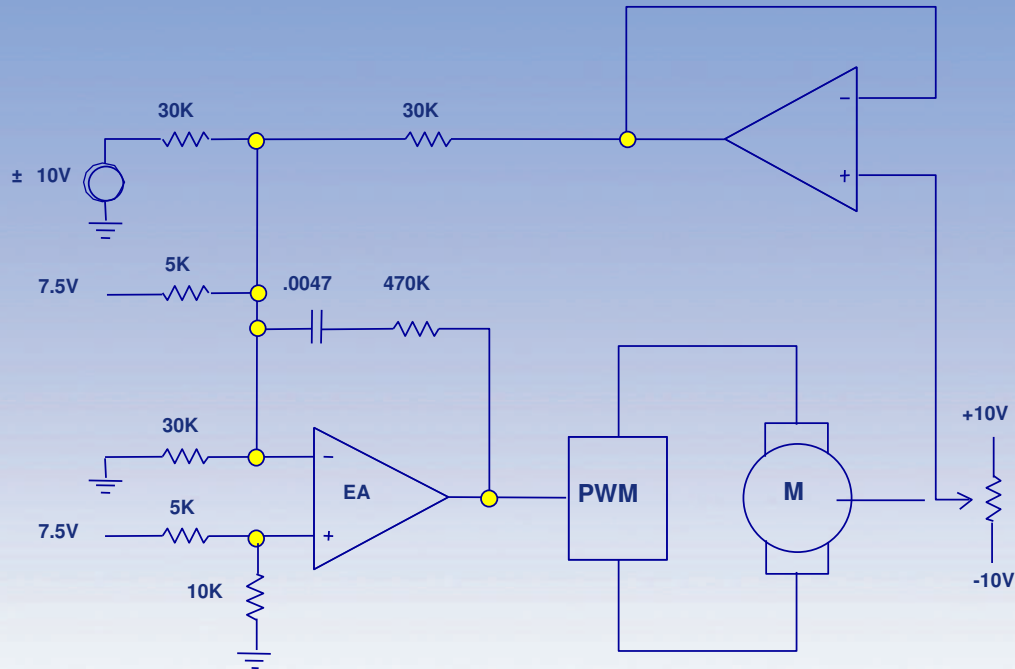

While one of the simplest forms of position sensing is shown here, options such as optical encoders, LVDT sensors, tachometers and variable capacitance transducers are all viable ways to sense speed or position. In a wider sense, this basic circuit can be adapted to control a wide variety of process variables such as temperature, flow rate, pressure, light intensity.....

The key elements in all these possible variations are the same:

- The PWM amplifiers controls the power

- The feedback circuit monitors the job

- The integrator forces the job to follow the command input

Note that the motor (and its load) are inside the feedback loop in this circuit. This means the frequency characteristics of these mechanical elements is inside the feedback loop and need to be considered when analyzing response and stability of the circuit.

Ref. AN30

The slide features a header with the APEX Microtechnology logo and a 'POWER FOR THE ANALOG WORLD' tagline. The main title is 'Compare: PWM & Linear Amps'. Below the title is a table with three columns: the parameter being compared, the PWM characteristic, and the Linear Amp characteristic.

Parameter	PWM	Linear Amp
V or I input	OK	OK
V or I output	OK	OK
Supplies	Single	Single/Dual
Max Power	Several KW	Fractional KW
Efficiency	High	Low
Noise	High	Low
Speed	Low	High

Think about the two previous pages a moment.

They are both basically op amp circuits where the driving op amp has a specialized output stage labeled PWM. In fact there are many applications where linear and PWM solutions would both work. The keys to the decision may be on the last two lines above: IF THE APPLICATION DOES NOT REQUIRE LOW NOISE AND HIGH SPEED, PWM AMPLIFIERS CAN PROVIDE A SOLUTION.

The next item to consider is cost. On a cost per watt capability basis, PWM amplifiers are generally less expensive than linears. With PWM capability starting at 200W, they are not the most likely candidates for a 5W job. At a few hundred watts, PWM amplifiers are very attractive. In between these levels, you may want to think more about the options because both linear and PWM amplifiers will likely work.

Ref. AN30