



DEFLECTION

- Electromagnetic
- Electrostatic
- Dynamic Focus Control

High speed power op amps are ideal candidates for all types of deflection uses. High current, high speed models are ideal for electromagnetic deflection. Models with rapid slew rates and extended supply ranges allow rapid di/dt of the yoke being driven. High voltage models are especially useful for electrostatic deflection and/or focus.

MAGNETIC DEFLECTION AMPLIFIER SELECTION

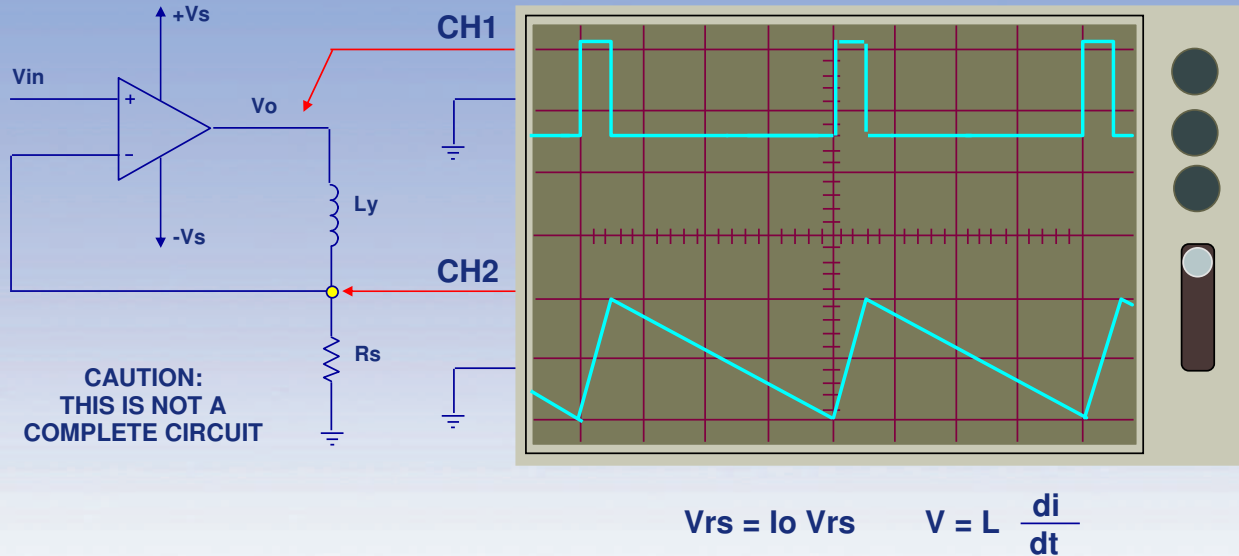

An amplifier selected for magnetic deflection must have an adequate slew rate and voltage rating to slew the current in the yoke fast enough.

These two considerations go hand in hand since the rate-of-change of current in the yoke is proportional to applied voltage. And the amplifier must slew to this applied voltage at least 10 times faster than the rate of change of current to achieve truly fast and accurate magnetic deflection.

Ref. AN5

ELECTRONIC DEFLECTION (V - I CIRCUIT)

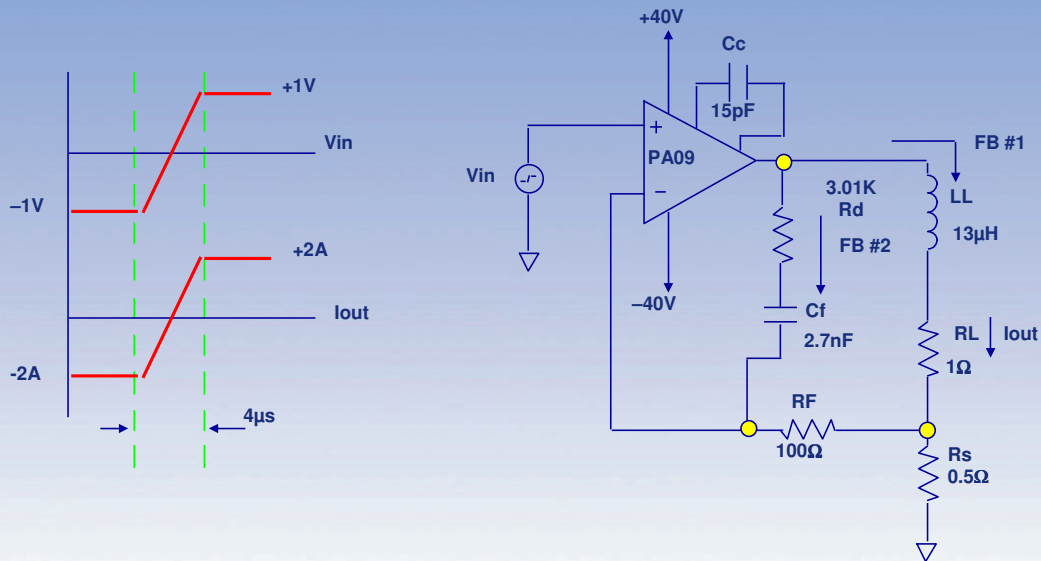

AMPLIFIER SELECTION

STEP 1: VOLTAGE

$$V_{LL} = LL \frac{Dip-p}{dt}$$

$$V_{LL} = 13\mu H \frac{4A}{4\mu s} = 13V$$

$$V_s = V_{LL} + V_{RL} + V_{R_s} + V_{sat}$$

$$V_{s \text{ MIN}} = 13V + 2V + 1V + 8V$$

$$\text{Where: } V_{RL} = I_p R_L$$

$$V_{s \text{ MIN}} = 24V$$

$$V_{R_s} = I_p R_s$$

STEP 2: CURRENT From desired Iout, current must be 2A.

STEP 3: SPEED

A design rule of thumb for good performance is to select an amplifier with a minimum slew rate equal to 10 times faster than the desired current slew rate, faster will be better.

$$S.R. \text{ MIN} = \frac{V_{s \text{ MIN}}}{(.1) dt}$$

$$S.R. \text{ MIN} = \frac{24V}{(.1) (4\mu s)} = 60V/\mu s$$

STEP 4: PA09 and PA19 meet or exceed these requirements. PA09 is less expensive. Ref. AN5

PA09 Deflection Setup

STABILITY FOR INDUCTIVE LOADS

MODEL	PA09-150	Note/PBs	Rin	9999999999 Kohms	Estimated Closure Frequency =	3162.278 KHz
Rs	0.5 Ohms	Rf	0.1 Kohms	Suggested maximum bandwidth	177827.9 Hz	
Lload	0.013 mH	Cf	2.7 nF	Estimated Closure Rate =	20.0 db/decade	
Rload	1 Ohms	Rd	3.01 Kohms	Estimated Phase Margin =	45.63 Degrees	
Is this a Composite?				No		

Notes:

R-C Pole Calculator +:				28 Print Data, Bode & Phase	29 Print Data, Bode, Phase & Parts
3.01 Kohms	Rd Kohms	1.16509	AC gain db	30	
20000 Hz	Rd Kohms	2.9	Rd Kohms	3.062278	
2.6438 nF	Cf nF	2.081381			

Ri/(Ri+Rf)	1
Equiv Z @ Rs	0.5 Ohms
Requiv/(Ri+Requiv)	0.333333333
DC Beta	0.333333333
DC Gain	9.542425094 db
Zero R/L	18364.0319 Hz
Rin Rf	0.1 Kohms
Zero Rd/Cf	19583.48013 Hz
AC Gain	29.85520778 db
Zero Cross	177827.941 Hz

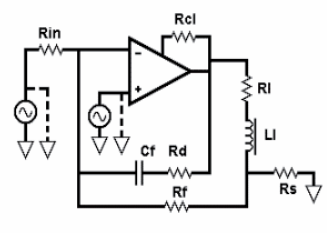
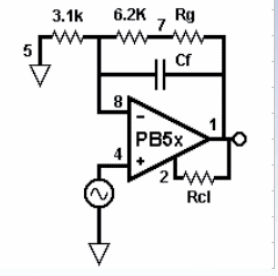
Set up the basic circuit in Power Design to see we have a 17 degree phase margin. Visualize the flat portion of feedback path #2 at about 30db. This is well below the intersection point and gives a nice round gain increase of 10x or 30 total. Estimate the line will cross the closed loop gain at about 200KHz.

Considering the inductor open and Cf shorted, AC gain will be roughly Rd/Rf. Put 3.01K and 20KHz (a decade below our estimated cross) in the R-C Pole Calculator. Enter 2.7nF for Cf.

We have good phase margin and an suggested maximum frequency of 178KHz. This suggestion is the lower of two criteria: The cross of the two feedback paths (the case here) or the frequency where loop gain is 20db (difference between open loop and closed loop gains).

Ref. AN38



V – I MAGNITUDE PLOT FOR STABILITY

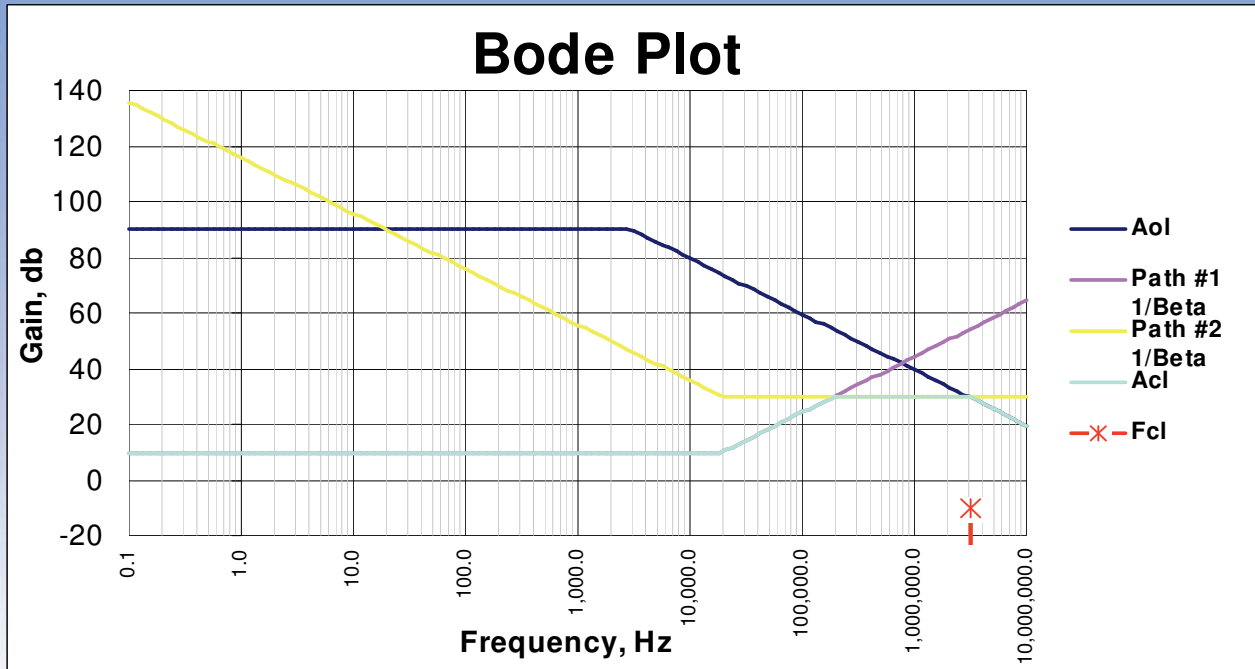

Ref. AN38

V - I OPEN LOOP PHASE PLOT FOR STABILITY

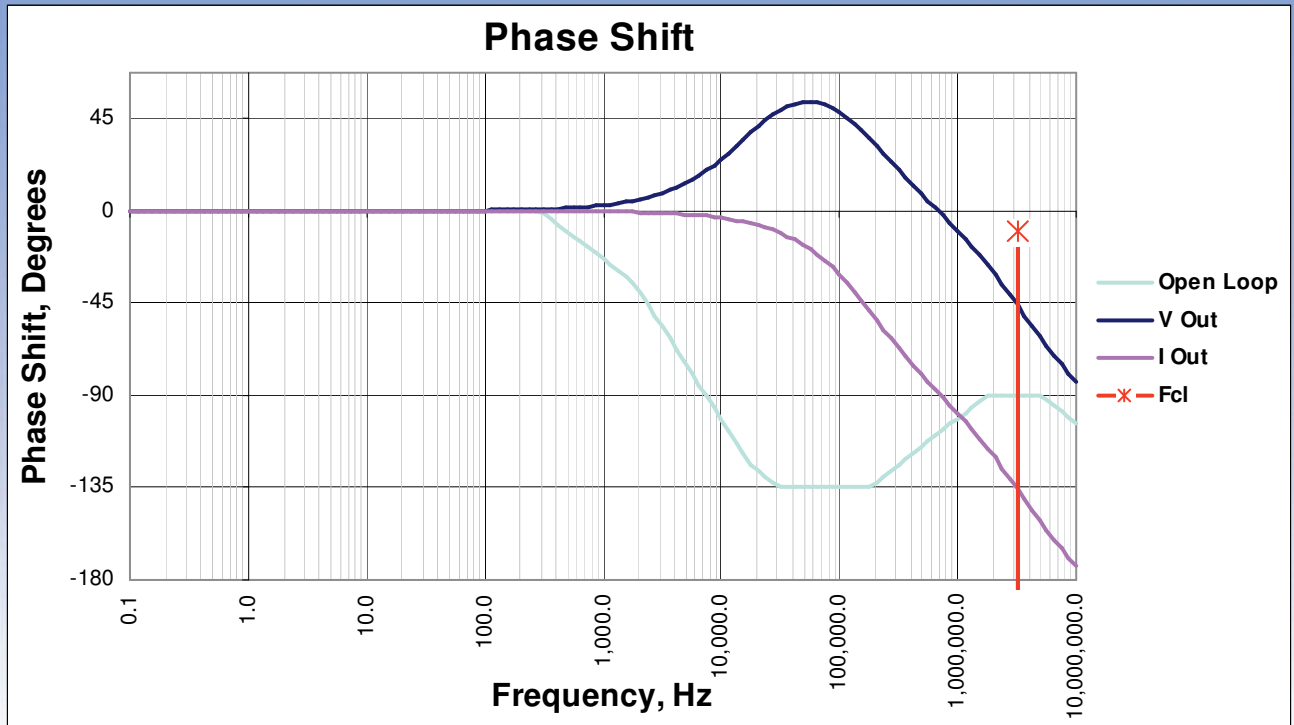

Ref. AN38

V-I Phase Components for Stability

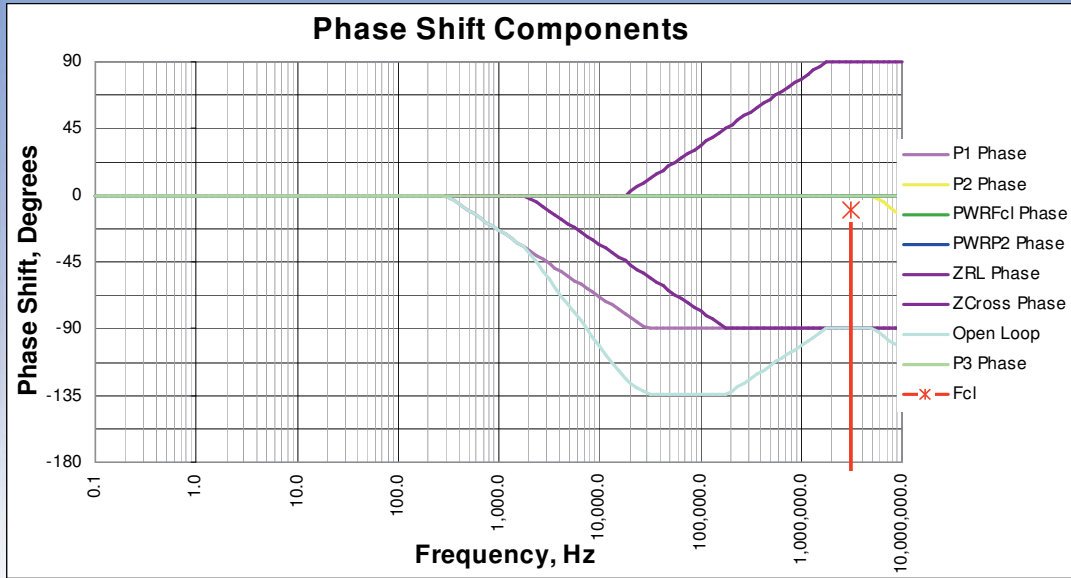

Ref. AN38

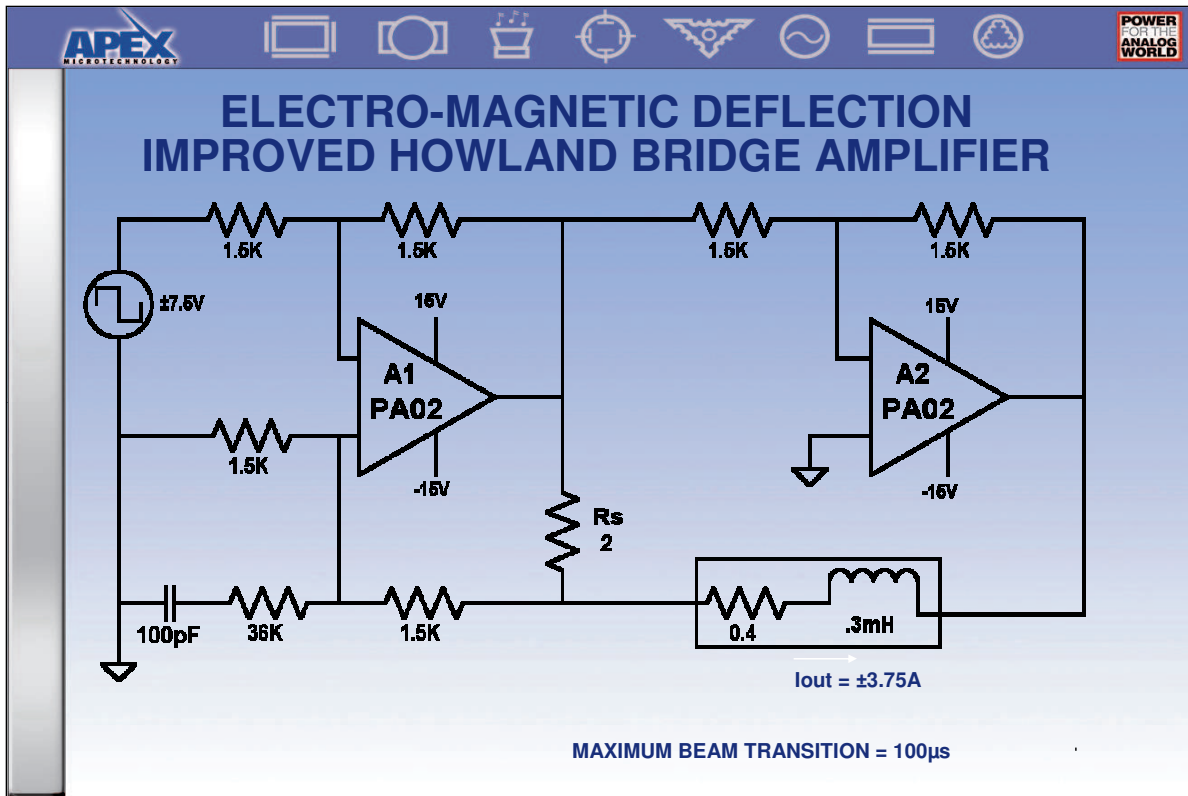

A1 is a Howland Current Pump, A2 provides a gain of -1 to drive the opposite terminal of the coil. A first glance, it might appear the choice of 2Ω for the sense resistor is quite large because the peak voltage drop across it is $7.5V$, or half the supply voltage.

Voltage across the inductor required to move the beam is given by:

$$V_L = L * \Delta I / \Delta t \qquad V_L = 300\mu H * 7.5A / 100\mu s = 22.5V$$

If one were to add to this the peak voltage drop across the coil resistance ($1.5V$) and the sense resistor ($7.5V$), it would be easy to assume a total swing of $31.5V$ or greater than $15V$ at $3.75A$ would be required of each amplifier.

Salvation for this problem lies in analyzing current flow direction.

Ref. AN5

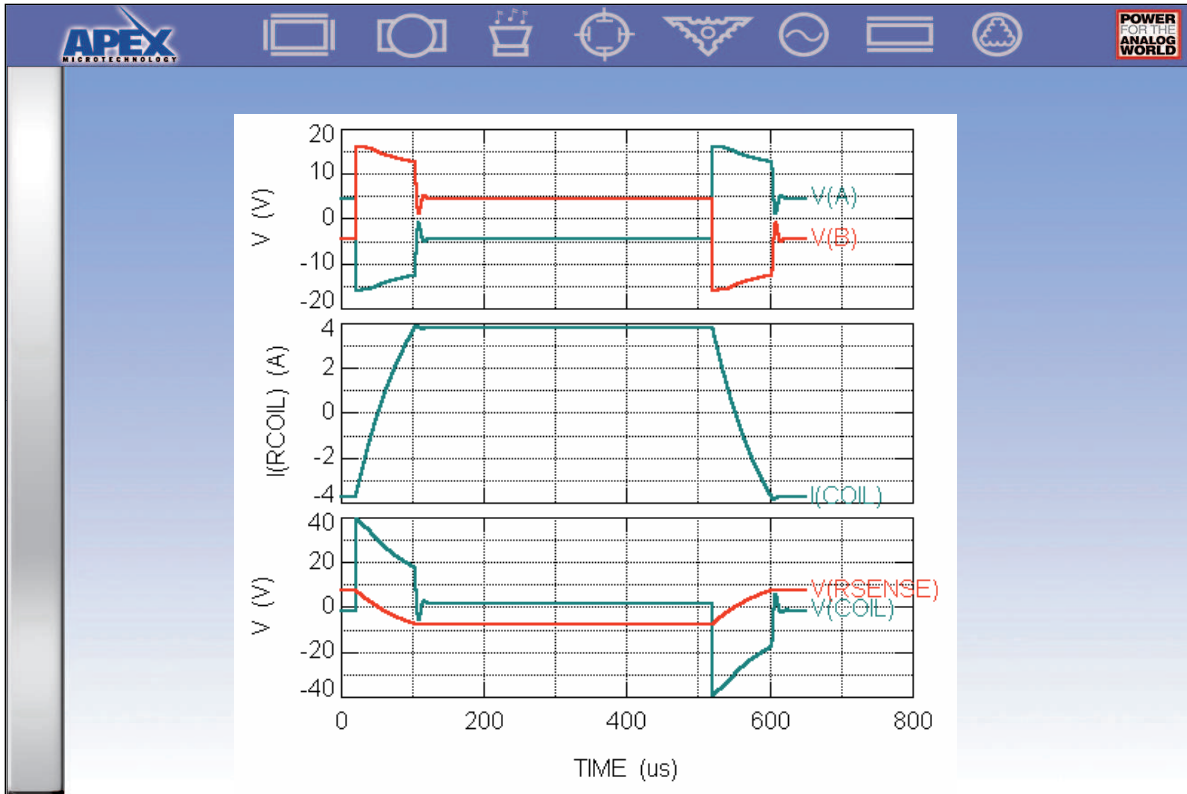

Check out the middle graph. Did you expect me to show you anything but a good current waveform? The main portion of the transition is complete in about $80\mu\text{s}$ and settles nicely.

In the top graph, we find surprise #1; both amplifiers are actually swinging OUTSIDE their supply rails. The “upside down” topology of the output transistors in the PA02 allows energy stored in the inductor to fly back, turning on the internal protection diodes. The result is peak voltages in the first portion of the transition greater than total supply.

In the bottom graph, we find surprise #2; stored energy in the inductor develops voltage across the sense resistor which ADDS to the op amp voltage until current crosses zero. In this manner, peak voltage across the coil is nearly 40V!

The seemingly large value of sense resistor did not kill us on voltage drive requirements and gives us two benefits: First, internal power dissipation is lower than with a smaller resistor. Secondly, with larger feedback signal levels, the amplifier closed loop gain is lower; loop gain is larger; fidelity of the current output is better; and voltage offset contributes a lower current offset error.

ELECTROSTATIC DEFLECTION AMPLIFIER

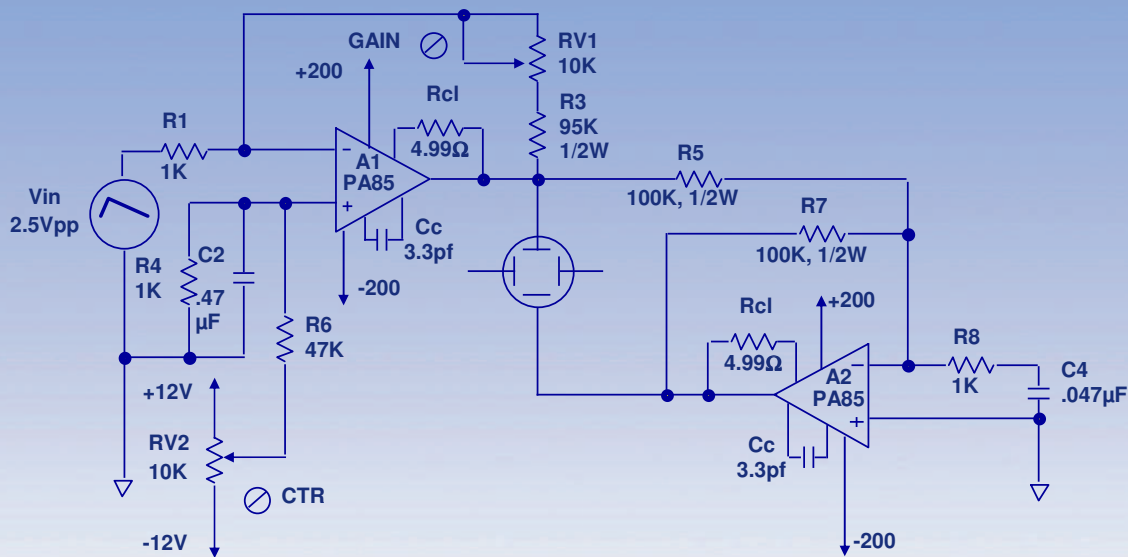

BALANCED TO MINIMIZE CRT DISTORTION

The PA85 was chosen for this application for its high voltage and high speed characteristics. Full bridge drive is utilized to provide a balanced drive to the CRT plate. Bridge drive is useful to reduce geometric distortion in electrostatic deflection applications.

A1 is the main amplifier operating at a gain of 100. This high gain permits minimal phase compensation for maximum speed performance.

Slave amplifier A2 is operated at a feedback factor of 1/2, that is an inverting unity gain. To get the same benefit of high speed that A1 enjoys due to the minimum compensation requirements, A2 is fooled into thinking it has a gain of 100 with the use of R8 and C4. This results in A2 having the same small signal bandwidth and high frequency gain as A1, which allows symmetrical bridge slew rates since A1 and A2 now use the same Cc compensation capacitor. This is the "Noise Gain Compensation" trick discussed earlier.

Ref. AN3

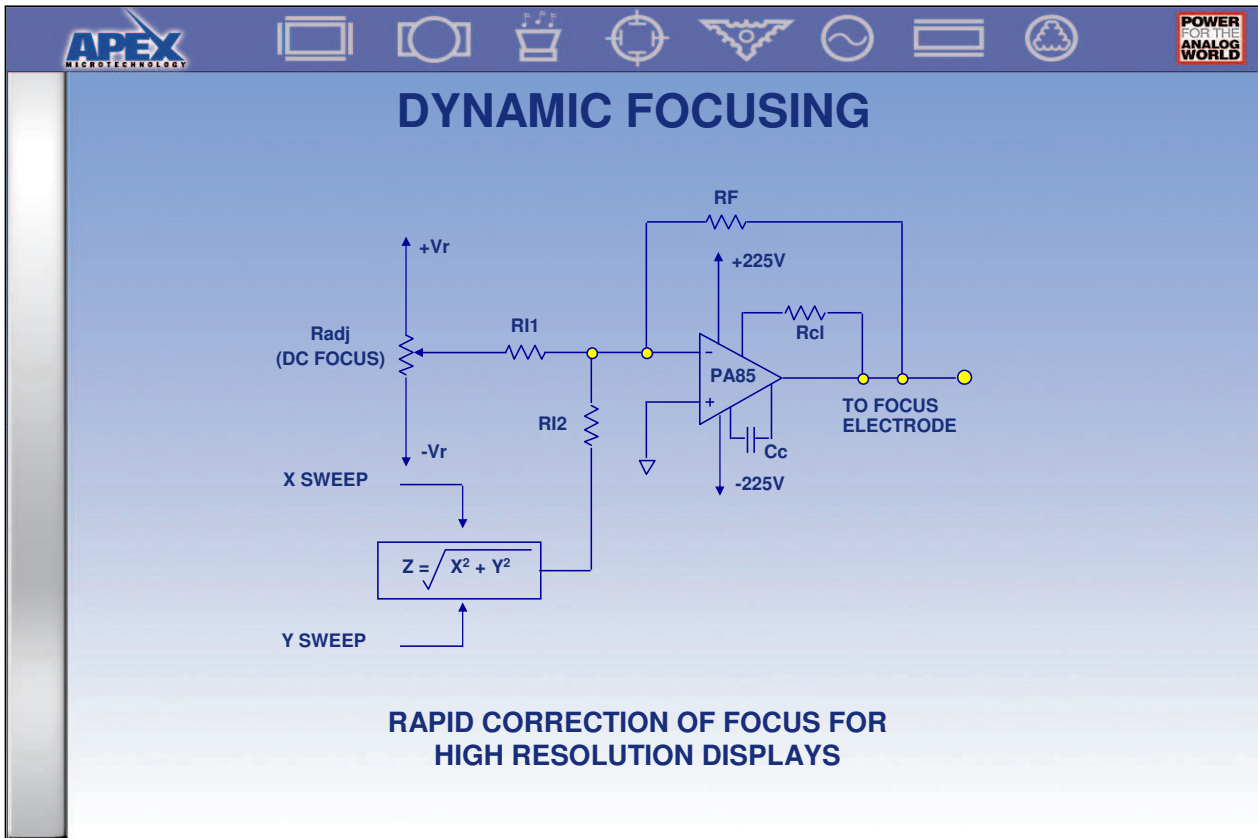

In a flat screen display system the distance from the source of the beam to the screen changes as it deflects on the screen, from left to right, and from top to bottom. As a result of this a dynamic focus is required to keep the beam in focus, no matter where it is located on the screen.

A normal CRT screen does not have to overcome these distance differences, since the distance from the source of the beam and the screen are the same no matter where you are on the screen, by virtue of the curvature of the screen.

To achieve electrostatic dynamic focus requires an amplifier with high voltage and high slew rate, as it is important to rapidly change the focus to keep the beam focused, regardless of screen position. The 450V, 1000V/ μ s slew rate PA85 is the ideal choice.

X and Y location sweep information is summed and scaled to provide the proper focus bias to the focus electrode. A DC offset sets the focus at the center of the screen.

Don't forget the heatsinking on the PA85 as the high slew rate requires a high quiescent current which in combination with the high power supply voltage will result in 11.25W of quiescent power dissipation. A PA85 can cook, from a slew rate standpoint, and will literally cook without proper heatsinking!