

## Voltage to Current Conversion

### VOLTAGE TO CURRENT CONVERSION

Voltage controlled current sources (or VCCS's) can be useful for applications such as active loads for use in component testing or torque control for motors. Torque control is simplified since torque is a direct function of current in a motor. Current drive in servo loops reduces the phase lag due to motor inductance and simplifies stabilizing of the loop.

VCCS's using power op amps will assume one of two basic forms, depending on whether or not the load needs to be grounded.

### CURRENT SOURCE: FLOATING LOAD

Figure 1A illustrates the basic circuit of a VCCS for a floating load. The load is actually in the feedback path.  $R_S$  is a current sense resistor that develops a voltage proportional to load current.

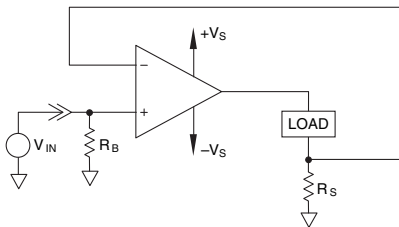

FIGURE 1A. BASIC VCCS FOR FLOATING LOAD

Note the inclusion of resistor  $R_B$  in Figure 1A and subsequent figures where non-inverting VCCS's are described. This resistor is present to prevent the non-inverting input from floating when the input voltage source is disconnected or goes to high impedance during the power on cycle.  $R_B$  provides a path for input bias current of the amplifier and commands the amplifier output current to zero in cases where  $V_{IN}$  is disconnected or goes to a high impedance. Figure 1B shows an implementation of a VCCS for a floating load. At low frequencies the added components  $C_f$ ,  $R_d$ , and  $R_F$  have no effect and are included only to insure stability. Considerations for these components are discussed in the section on "Stabilizing the Floating Load VCCS" covered later in this application note.

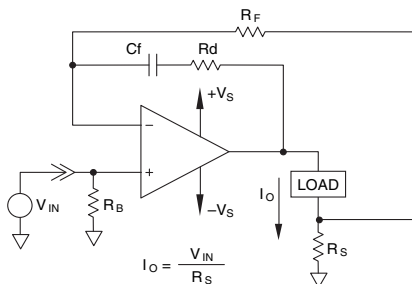

FIGURE 1B. VCCS FOR FLOATING LOAD WITH STABILITY COMPENSATION

The amplifier's loop gain will force the voltage across  $R_S$  to assume a value equal to the voltage applied to the non-inverting input, resulting in a transfer function of:

$$I_O = V_{IN} / R_S$$

Several variations are possible for this basic circuit. It is not necessary to have a direct feedback connection from  $R_S$  to the inverting input; components can be included to raise the gain of the circuit. Figure 2 shows a higher gain version with its equivalent transfer function. Higher gain circuits will lose some accuracy and bandwidth, but can be easier to stabilize.

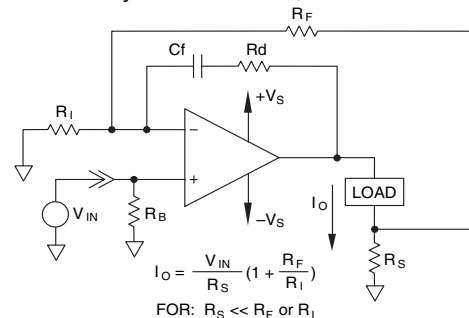

FIGURE 2. VCCS FOR FLOATING LOAD; INCREASED GAIN CONFIGURATION

Figure 3 shows an inverting VCCS. The input voltage results in an opposite polarity of current output. Just as in the case of inverting voltage amplifiers, the advantage of not having any common mode variation at the amplifier input is higher accuracy and lower distortion.

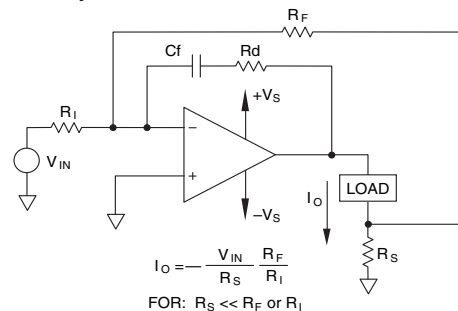

FIGURE 3. VCCS FOR FLOATING LOAD; INVERTING CONFIGURATION

Figure 4 is a current input version which is actually a CCCS, or current controlled current source. This is truly a current amplifier. This circuit could be useful with current output Digital-to-Analog Converters (DAC's), or in any application where a current is available as an input.

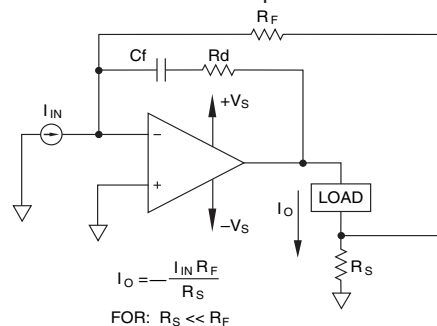

FIGURE 4. CCCS FOR FLOATING LOAD; INVERTING CONFIGURATION

**STABILIZING THE FLOATING LOAD VCCS**

Because the load is in the feedback loop on all of these circuits, it will have a significant effect on stability. If the load was always purely resistive, the analysis would be simple and many circuits would not require any additional components (such as Cf and Rd) to insure stability. In the real world however, we usually find ourselves using these circuits to drive such complex loads as magnetic coils and motors.

Stability analysis is most easily accomplished using “Rate of Closure” techniques where the response of the the feedback is plotted against the amplifier open loop gain. This technique uses information easily obtained on any amplifier data sheet.

Rate-of-closure refers to how the response of the feedback and amplifier Aol intersect. If the slope of the combined intersection is not over 20 dB per decade, the circuit will be stable.

For an example, consider the amplifier of Figure 1A. Assume a PA07 amplifier with a 0.5 ohm current sense resistor will be used to drive a 50 μH coil with 1 ohm of series resistance. In Figure 5 we have superimposed on the Aol graph of the PA07 the response of the load and sense resistor.

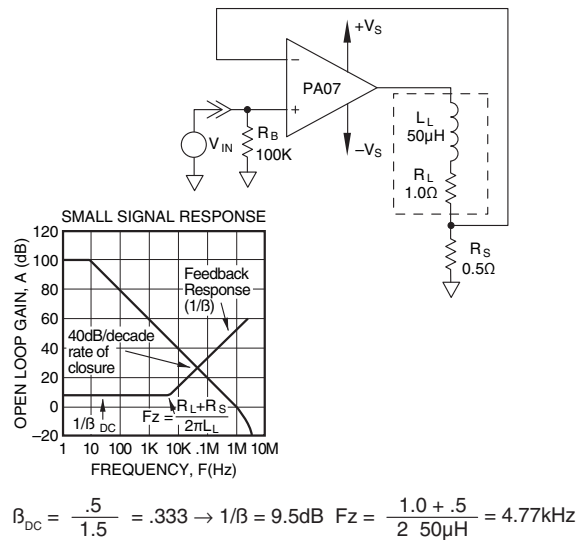

FIGURE 5. PLOTTING FEEDBACK RESPONSES

The intersection of the responses exhibits a combined slope of 40 dB per decade, leading to ringing or outright oscillation. Let’s refer to that point as the “critical intersection frequency.” Compensation for this circuit is best accomplished with an alternate feedback path; the response of which will dominate at the critical intersection frequency.

A good criteria for the response of the alternate feedback would be:

1. A response which dominates by at least an order of magnitude (20 dB) at the critical intersection frequency.
2. The alternate feedback response should have a corner occurring at a frequency an order of magnitude less than the critical intersection frequency.

To provide this response, the alternate feedback components have been selected to provide the compensating response illustrated in Figure 6. AB in Figure 6 is the dominant feedback path the amplifier will see in its closed loop configuration. RF merely acts as a ground leg return impedance for the alternate feedback loop, and should be a low value between 100 and 1000 ohms. Rd is then selected to provide the desired high frequency gain, and Cf is selected for the alternate feedback

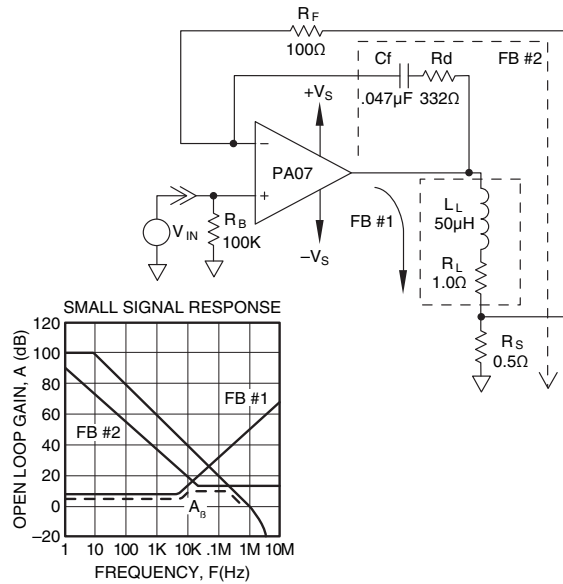

FIGURE 6. COMPENSATING THE AMPLIFIER corner.

Note that these are similar to techniques used to stabilize magnetic deflection amplifiers described in Apex Precision Power AN05, “Precision Magnetic Deflection.”

**CURRENT OUTPUT FOR GROUNDED LOAD**

The VCCS for a grounded load is sometimes referred to as the “Improved Howland Current Pump.” It is actually a differential amplifier which senses both input signal and feedback differentially.

Figure 7 shows a general example for this VCCS with its associated transfer function.

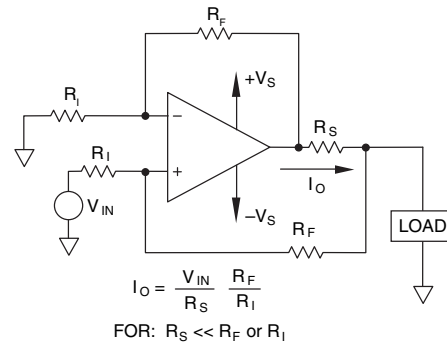

FIGURE 7. VCCS FOR A GROUNDED LOAD

First among the special considerations for this circuit is that the two input resistors (R1), and the two feedback resistors (RF), must be closely matched. Even slight mismatching will cause large errors in the transfer function and degrade the output impedance causing the circuit to become less of a true current source.

As an example of the matching requirement, consider the actual example using PA07 in Figure 8. Matching the resistors as closely as tolerances permitted produced an output impedance of 43 K ohms. A 1% mismatch reduced output impedance to 200 ohms and introduced nearly 20% error into the transfer function.

This suggests that matching to better than 0.1% is required which is probably best accomplished with prepackaged resis-

tor networks with excellent ratio match. The circuit of Figure 8 actually required a slight amount of mismatch in the two ( $R_F$ ) resistors to compensate for mismatches elsewhere, suggesting that the inclusion of a trimpot may be necessary to obtain maximum performance.

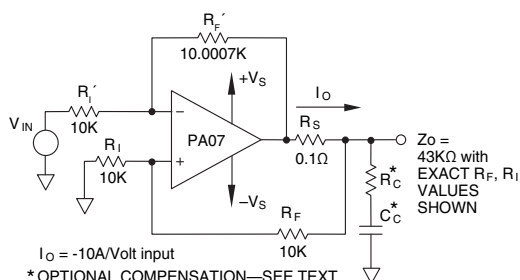

FIGURE 8. ACTUAL PA07 VCCS

**STABILITY WITH THE GROUNDLED LOAD CIRCUIT**

The grounded load circuit is remarkably forgiving from a stability standpoint. Generally, no additional measures need to be taken to insure stability.

Any stability problems that do arise are likely to be a result of the output impedance of the circuit appearing capacitive. The equivalent capacitance can be expressed as follows:

$$C_{eq} = \frac{R_1 + R_F}{2\pi f_o R_1 R_S}$$

Where:  $f_o$  = THE GAIN-BANDWIDTH PRODUCT OF THE AMPLIFIER

This capacitance can resonate with inductive loads, resulting most often in ringing problems with rapid transitions. The only effective compensation is a simple “Q-snubber” technique: determine the resonant frequency of the inductive load and output capacitance of the circuit. Then, select a resistor value one-tenth the reactance of the inductor at the resonant frequency. Add a series capacitor with a reactance at the resonant frequency equal to one-tenth of the resistor value. An alternate method would be to put a small inductor and damping resistor in series with  $R_S$ .

Also keep in mind that the equation favors larger values of  $R_1$  and  $R_S$ , and the use of op amps with better gain-bandwidth to reduce effective capacitance. In circuits where good high frequency performance is required, this will necessitate increasing either or both  $R_1$  and  $R_S$  with the upper limits being established where stray capacitance and amplifier input capacitance become significant.

An infrequent second cause of instability in this circuit is due to negative resistance in the output impedance characteristic of the circuit. This problem can be solved by trimming the feedback resistors to improve matching.

**THE CURRENT MIRROR**

The current mirror circuit is a handy device for generating a second current that is proportional to input current but opposite in direction.

The mirror in Figure 9 must be driven from a true current source in order to have flexible voltage compliance at the input. Any input current will attempt to develop a drop across  $R_1$  which will be matched by the drop across  $R_2$  causing the current through  $R_2$  to be ratioed to that in  $R_1$ . For example, if  $R_1$  were 1.0 K ohm and  $R_2$  were 1 ohm, then 1 mA of input

current will produce 1 Amp of output current.

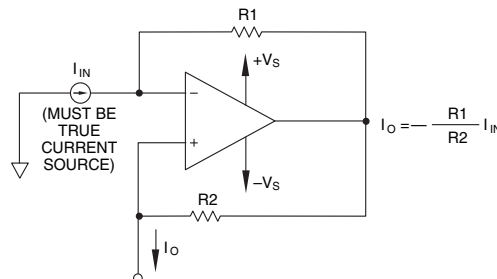

FIGURE 9. CURRENT MIRROR

**RATE-OF-CLOSURE AND FEEDBACK RESPONSE**

Rate-of-closure stability analysis techniques are a method of plotting feedback response against amplifier response to determine stability.

The closed loop gain of any feedback amplifier is given by:

$$A_{cl} = A_{ol} / (1 - \beta A_{ol})$$

Where:  $A_{ol}$  IS THE OPEN-LOOP GAIN OF THE AMPLIFIER, AND  $A_{cl}$  IS THE RESULTANT CLOSED LOOP GAIN

$\beta$  is a term describing the attenuation from the output signal to the signal fed back to the input (see Figure 10). In other words,  $\beta$  is the ratio of voltage fed back to the amplifier over the amplifier’s output voltage. ( $V_{feedback} = \beta V_{out}$ )

In the examples used in this application note, the plotting of  $\beta$  versus amplifier response is facilitated by plotting an equivalent closed loop response ( $1/\beta$ ) of the amplifier circuit and superimposing this response on the amplifier open loop response. This “**equivalent closed loop response**” is also referred to as noise gain,  $A_v(n)$ .

In the example in Figure 5, the curve referred to as feedback response is actually representative of the closed loop noise gain response of the amplifier due to the feedback network consisting of yoke and sense resistor. In Figure 6, an additional feedback response for  $C_f$ ,  $R_d$ , and  $R_F$  is plotted independently of all other responses. There are several important points to be noted in the use of these graphs:

1. In the case of multiple feedback networks such as in Figure 6, the response with the lowest noise gain at any given frequency will be the dominant feedback path. In Figure 6 this dominant feedback path is labelled  $A_{\beta}$ .
2. Whenever the noise gain and open loop gain intersect with a combined slope, or rate of closure, exceeding 20 dB/decade, poor stability will result. 40 dB/decade will definitely oscillate since this represents 180 degrees of phase shift. An example of this is shown in Figure 5.

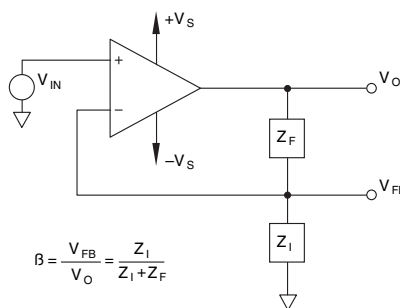

FIGURE 10. FEEDBACK FACTOR,  $\beta$

---

## CONTACTING CIRRUS LOGIC SUPPORT

For all Apex Precision Power product questions and inquiries, call toll free 800-546-2739 in North America.

For inquiries via email, please contact [apex.support@cirrus.com](mailto:apex.support@cirrus.com).

International customers can also request support by contacting their local Cirrus Logic Sales Representative.

To find the one nearest to you, go to [www.cirrus.com](http://www.cirrus.com)

---

### IMPORTANT NOTICE

Cirrus Logic, Inc. and its subsidiaries ("Cirrus") believe that the information contained in this document is accurate and reliable. However, the information is subject to change without notice and is provided "AS IS" without warranty of any kind (express or implied). Customers are advised to obtain the latest version of relevant information to verify, before placing orders, that information being relied on is current and complete. All products are sold subject to the terms and conditions of sale supplied at the time of order acknowledgment, including those pertaining to warranty, indemnification, and limitation of liability. No responsibility is assumed by Cirrus for the use of this information, including use of this information as the basis for manufacture or sale of any items, or for infringement of patents or other rights of third parties. This document is the property of Cirrus and by furnishing this information, Cirrus grants no license, express or implied under any patents, mask work rights, copyrights, trademarks, trade secrets or other intellectual property rights. Cirrus owns the copyrights associated with the information contained herein and gives consent for copies to be made of the information only for use within your organization with respect to Cirrus integrated circuits or other products of Cirrus. This consent does not extend to other copying such as copying for general distribution, advertising or promotional purposes, or for creating any work for resale.

CERTAIN APPLICATIONS USING SEMICONDUCTOR PRODUCTS MAY INVOLVE POTENTIAL RISKS OF DEATH, PERSONAL INJURY, OR SEVERE PROPERTY OR ENVIRONMENTAL DAMAGE ("CRITICAL APPLICATIONS"). CIRRUS PRODUCTS ARE NOT DESIGNED, AUTHORIZED OR WARRANTED TO BE SUITABLE FOR USE IN PRODUCTS SURGICALLY IMPLANTED INTO THE BODY, AUTOMOTIVE SAFETY OR SECURITY DEVICES, LIFE SUPPORT PRODUCTS OR OTHER CRITICAL APPLICATIONS. INCLUSION OF CIRRUS PRODUCTS IN SUCH APPLICATIONS IS UNDERSTOOD TO BE FULLY AT THE CUSTOMER'S RISK AND CIRRUS DISCLAIMS AND MAKES NO WARRANTY, EXPRESS, STATUTORY OR IMPLIED, INCLUDING THE IMPLIED WARRANTIES OF MERCHANTABILITY AND FITNESS FOR PARTICULAR PURPOSE, WITH REGARD TO ANY CIRRUS PRODUCT THAT IS USED IN SUCH A MANNER. IF THE CUSTOMER OR CUSTOMER'S CUSTOMER USES OR PERMITS THE USE OF CIRRUS PRODUCTS IN CRITICAL APPLICATIONS, CUSTOMER AGREES, BY SUCH USE, TO FULLY INDEMNIFY CIRRUS, ITS OFFICERS, DIRECTORS, EMPLOYEES, DISTRIBUTORS AND OTHER AGENTS FROM ANY AND ALL LIABILITY, INCLUDING ATTORNEYS' FEES AND COSTS, THAT MAY RESULT FROM OR ARISE IN CONNECTION WITH THESE USES.

Cirrus Logic, Cirrus, and the Cirrus Logic logo designs, Apex Precision Power, Apex and the Apex Precision Power logo designs are trademarks of Cirrus Logic, Inc. All other brand and product names in this document may be trademarks or service marks of their respective owners.

---